

ELEVATIONS

THREE ELEVATION THEMES HAVE BEEN SELECTED FOR THIS COMMUNITY: TRANSITIONAL RANCH, FARMHOUSE AND COTTAGE. THE STYLES, ALTHOUGH DIFFERENT, ARE HARMONIOUS IN THAT THEY SHARE A COMMON AGRICULTURAL HERITAGE REINTERPRETED TO CREATE A LASTING CONTRIBUTION TO THE COMMUNITY. THIS IS ACHIEVED THROUGH APPROPRIATE USES OF EXTERIOR MATERIAL, ARTICULATION OF ENTRY DETAILS (ARCHES, POSTS, AND PORCHES) ALONG WITH VARYING ROOF PITCHES SPECIFIC TO EACH STYLE.

TRANSITIONAL RANCH

THE TRANSITIONAL RANCH USES A LOW ROOF PITCH AND HAS GABLE END ACCENTS, SHUTTERS, AND POTSHelves AT SELECT LOCATIONS.

FARMHOUSE

THE FARMHOUSE IS A CLASSIC STYLE USING STEEP ROOF PITCHES ALONG WITH BOARD AND BATTEN ACCENTS AND APPROPRIATELY THEMED LIGHTING.

COTTAGE

THE COTTAGE ALSO HAS STEEP ACCENT ROOFS AND HANDSOME SHUTTERS TO ACCENT THE WINDOWS AND IN THE CASE OF PLANS 1 AND 3 HAVE A GRACEFUL SOFT ARCH TO HIGHLIGHT THE ENTRY.

THEME SPECIFIC COACH LIGHTS, FRONT DOORS AND GARAGE DOORS ADD THE FINISHING TOUCHES TO THIS PLAN SERIES.

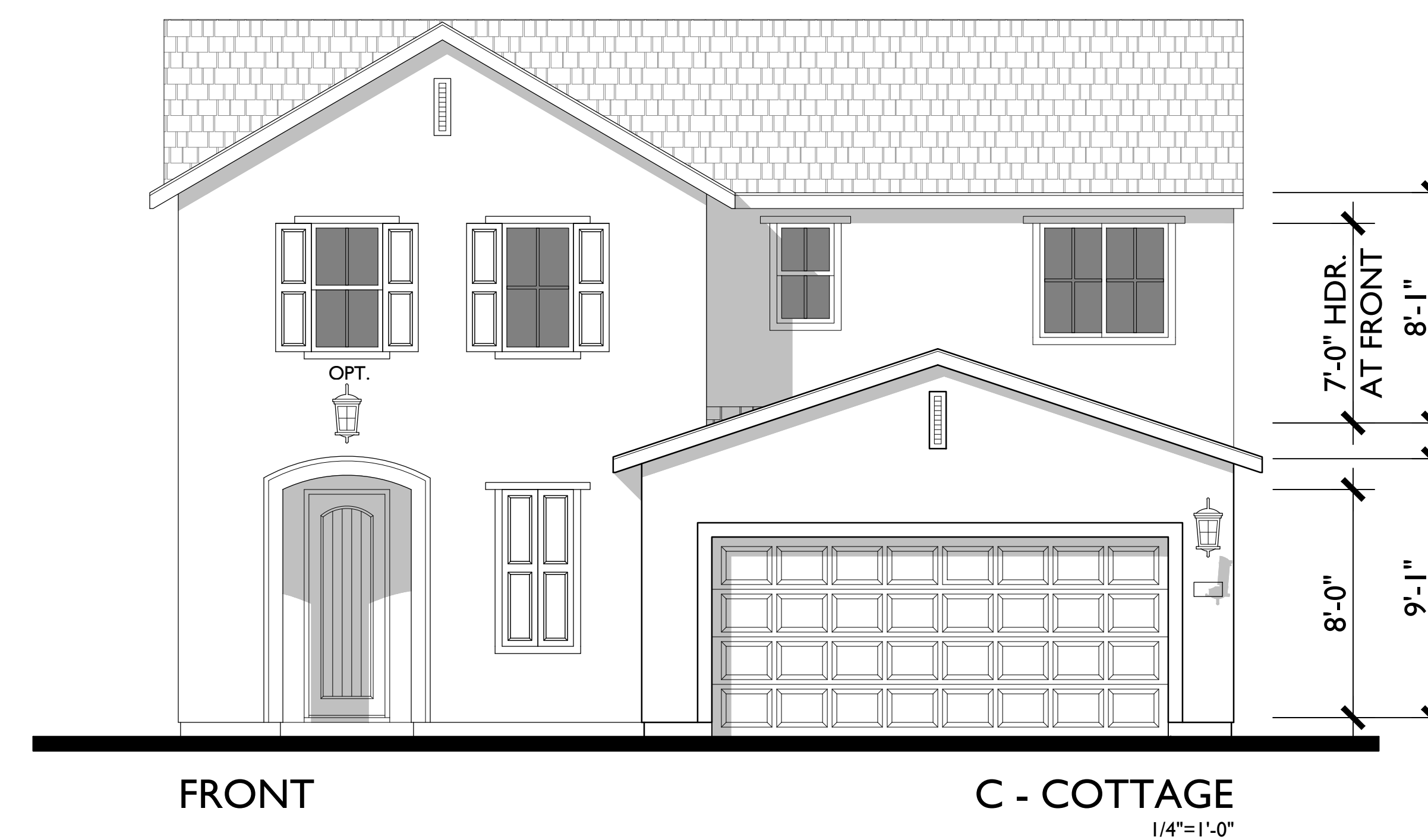
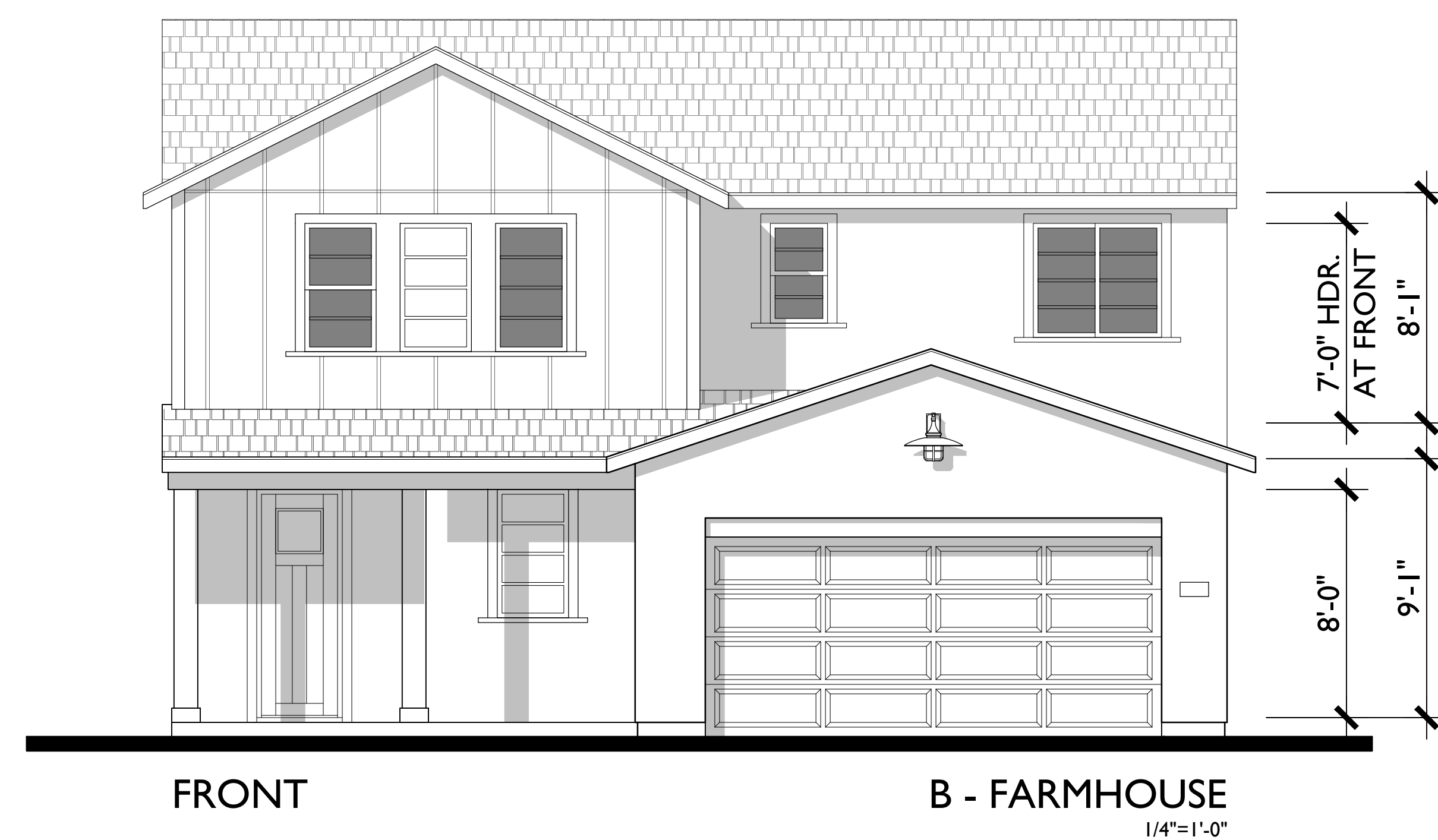

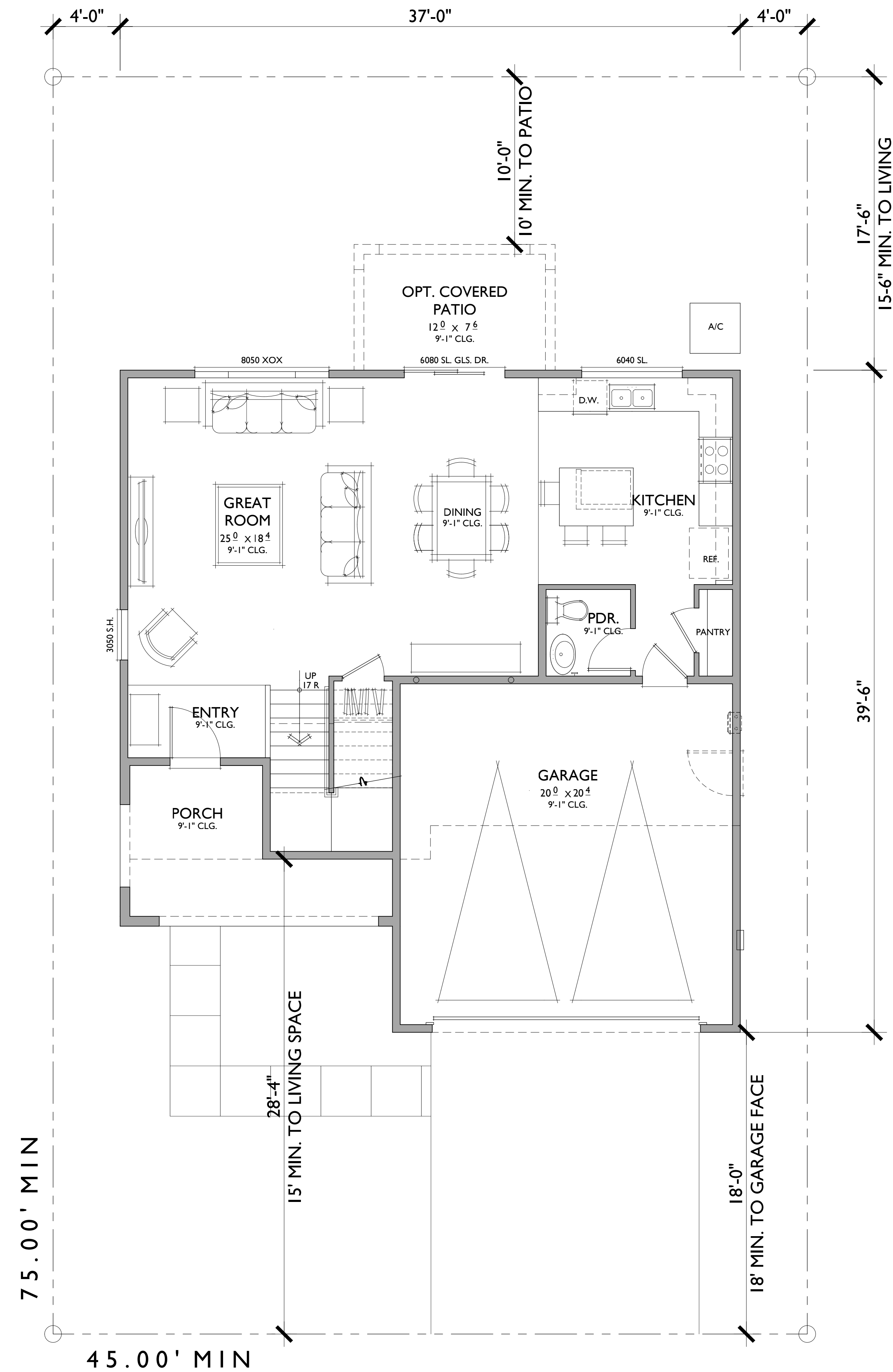
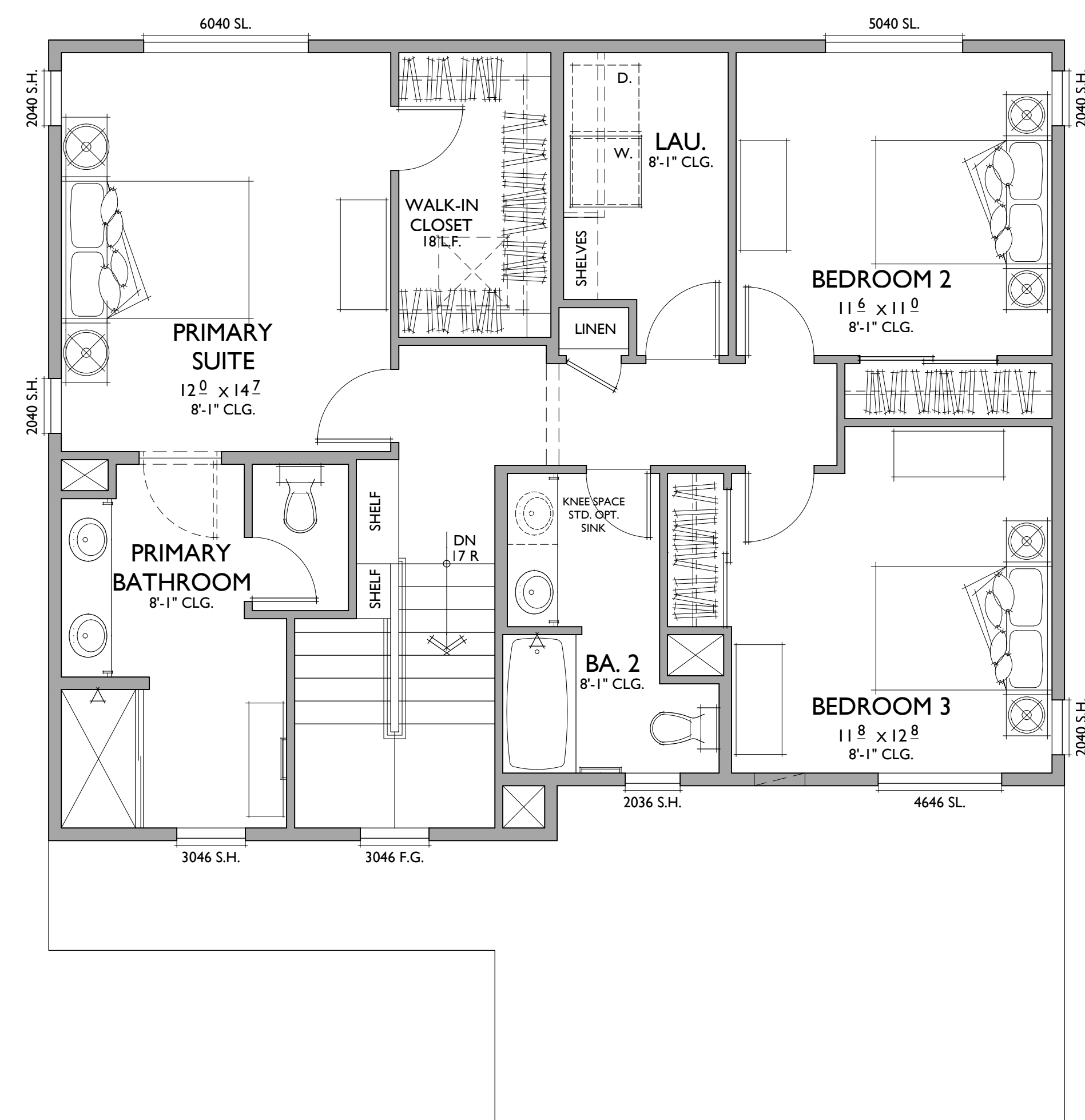

PLAN IA
1,788 SQ. FT.
 TARGET: 1,750 SQ. FT.
 3 BEDROOMS / 2.5 BATHS
 2 - CAR GARAGE

FLOOR AREA TABLE	
1ST FLOOR	819 SQ. FT.
2ND FLOOR	969 SQ. FT.
TOTAL LIVING	1,788 SQ. FT.
2 - CAR GARAGE	427 SQ. FT.
PORCH	112 SQ. FT.
OPT. COVERED PATIO	90 SQ. FT.

NOTE: SQUARE FOOTAGE MAY VARY DUE TO METHOD OF CALCULATION

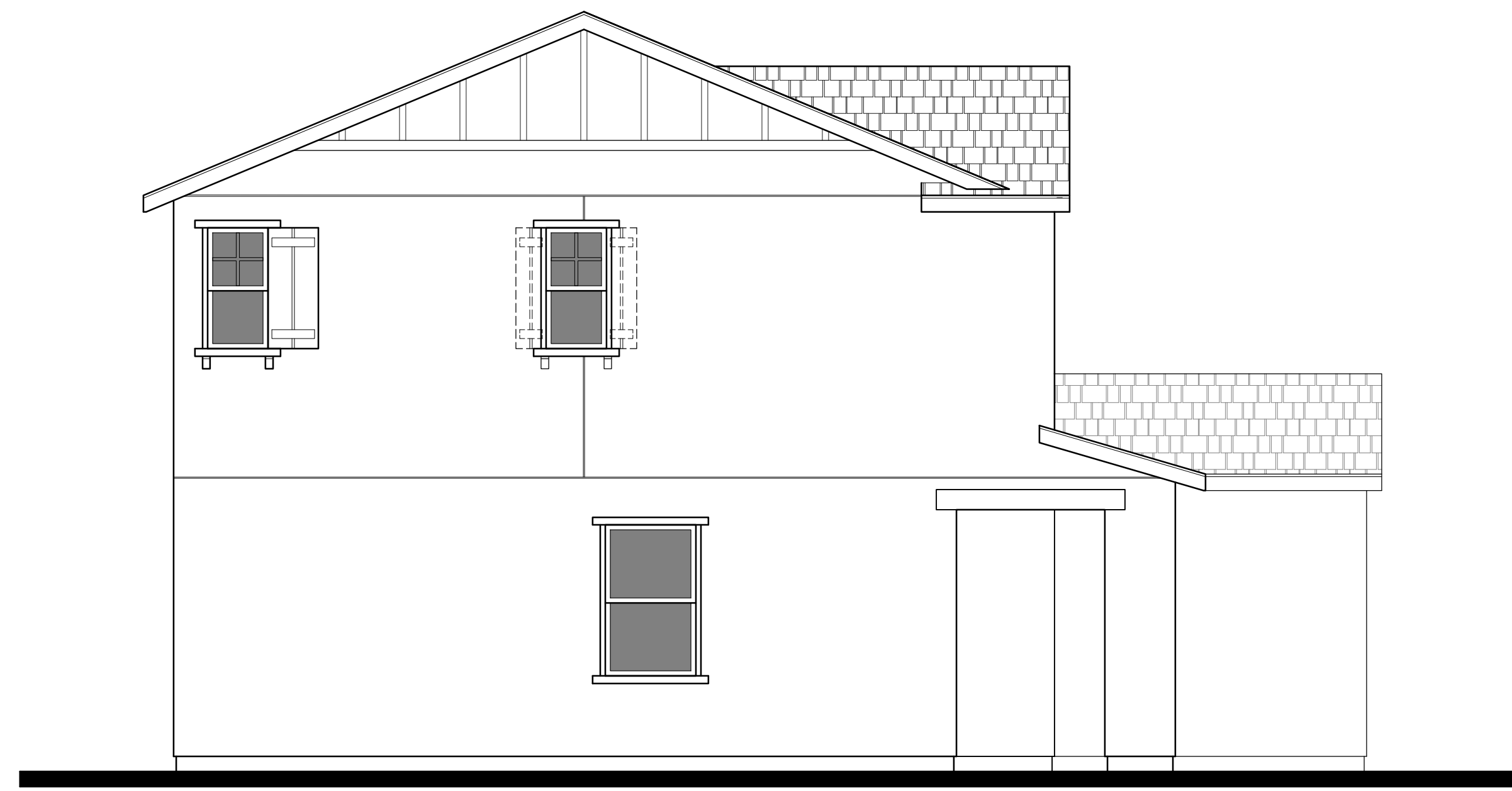

LEFT



FRONT

A - TRANSITIONAL RANCH

1/4"=1'-0"

7'-0" HDR.
AT FRONT
8'-1"
8'-0"
9'-1"

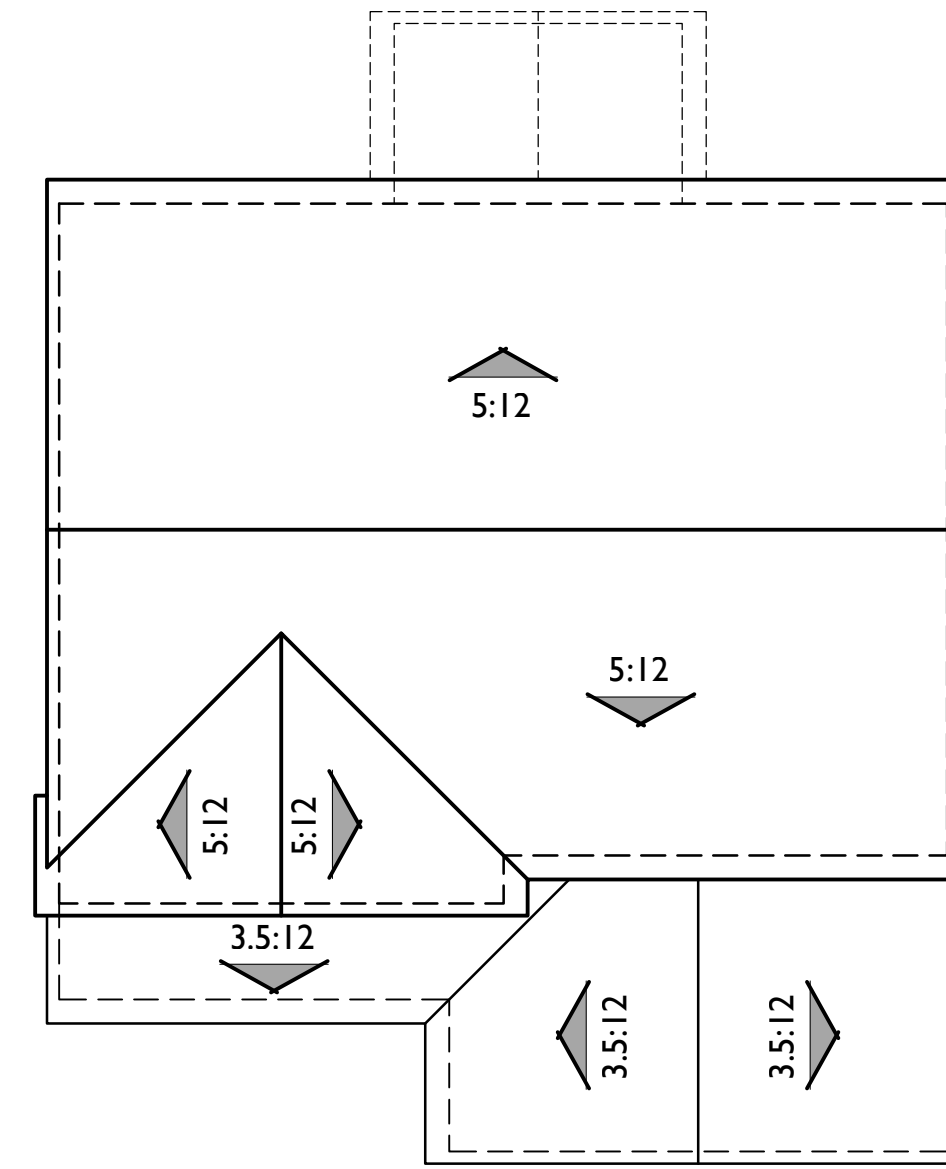

ROOF PLAN A

PITCH: 5:12 U.N.O.
RAKE: 6"
EAVE: 12"
ROOF MATERIAL: CONCRETE FLAT TILE

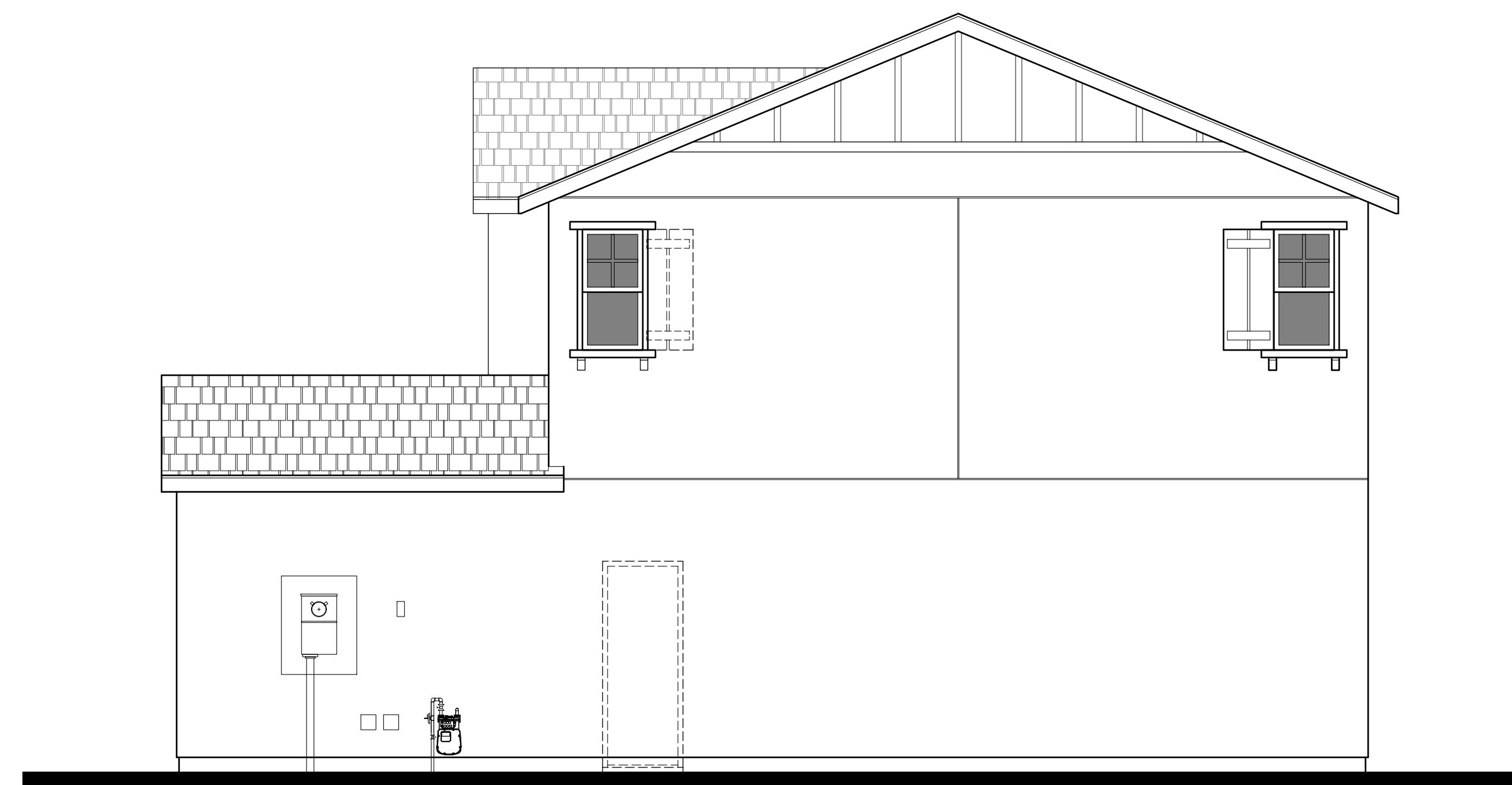

RIGHT

DASHED ENHANCEMENTS AT LOTS VISIBLE TO PUBLIC WALKWAYS, DRIVES AND PARKS. PLEASE VERIFY PER CIVIL PLOT PLAN.

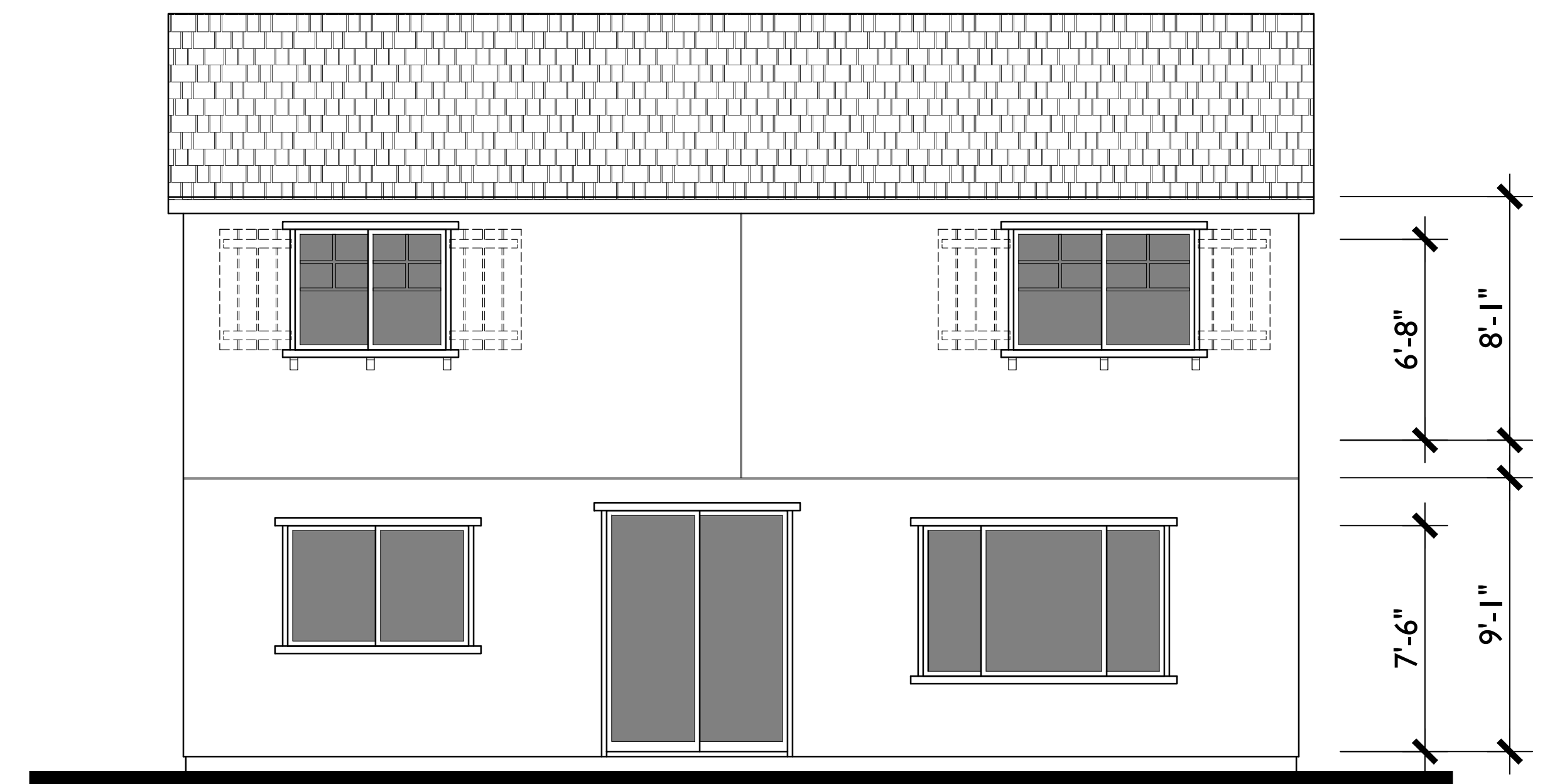

REAR

6'-8"
8'-1"
7'-6"
9'-1"

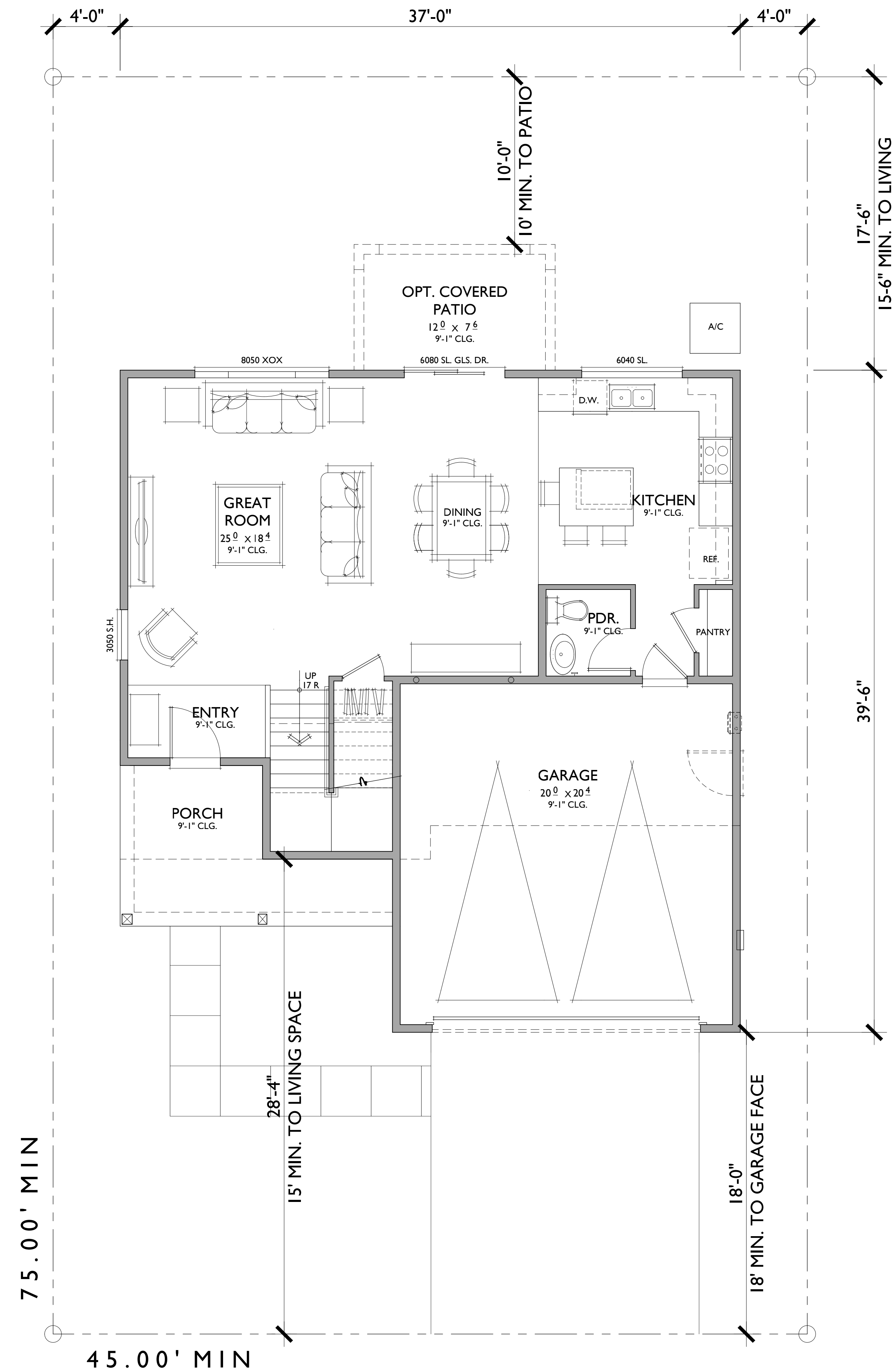
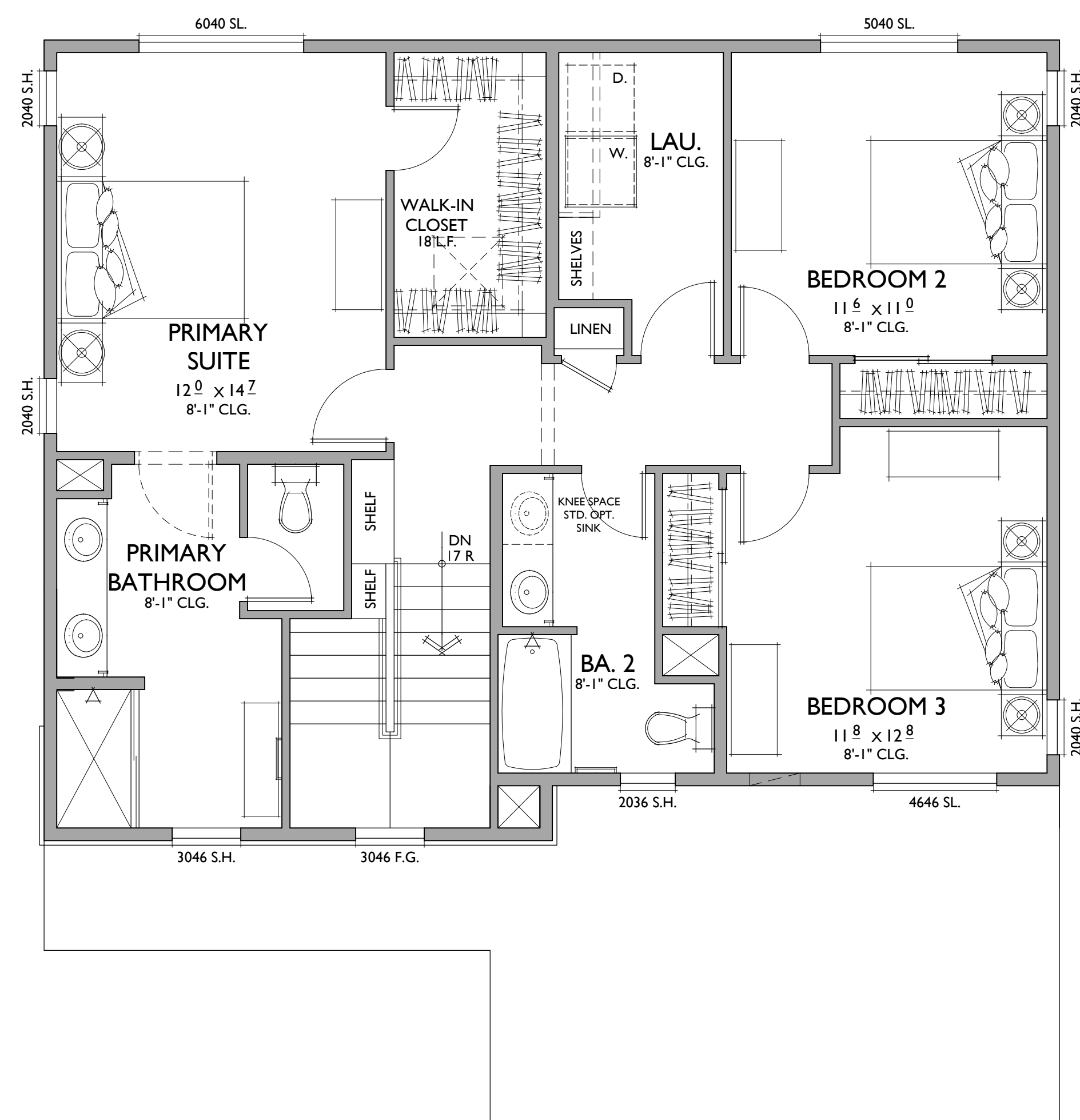

PLAN IB
1,786 SQ. FT.

TARGET: 1,750 SQ. FT.
 3 BEDROOMS / 2.5 BATHS
 2 - CAR GARAGE

FLOOR AREA TABLE

1ST FLOOR	818 SQ. FT.
2ND FLOOR	969 SQ. FT.
TOTAL LIVING	1,786 SQ. FT.
2 - CAR GARAGE	428 SQ. FT.
PORCH	112 SQ. FT.
OPT. COVERED PATIO	90 SQ. FT.

NOTE: SQUARE FOOTAGE MAY VARY DUE TO METHOD OF CALCULATION

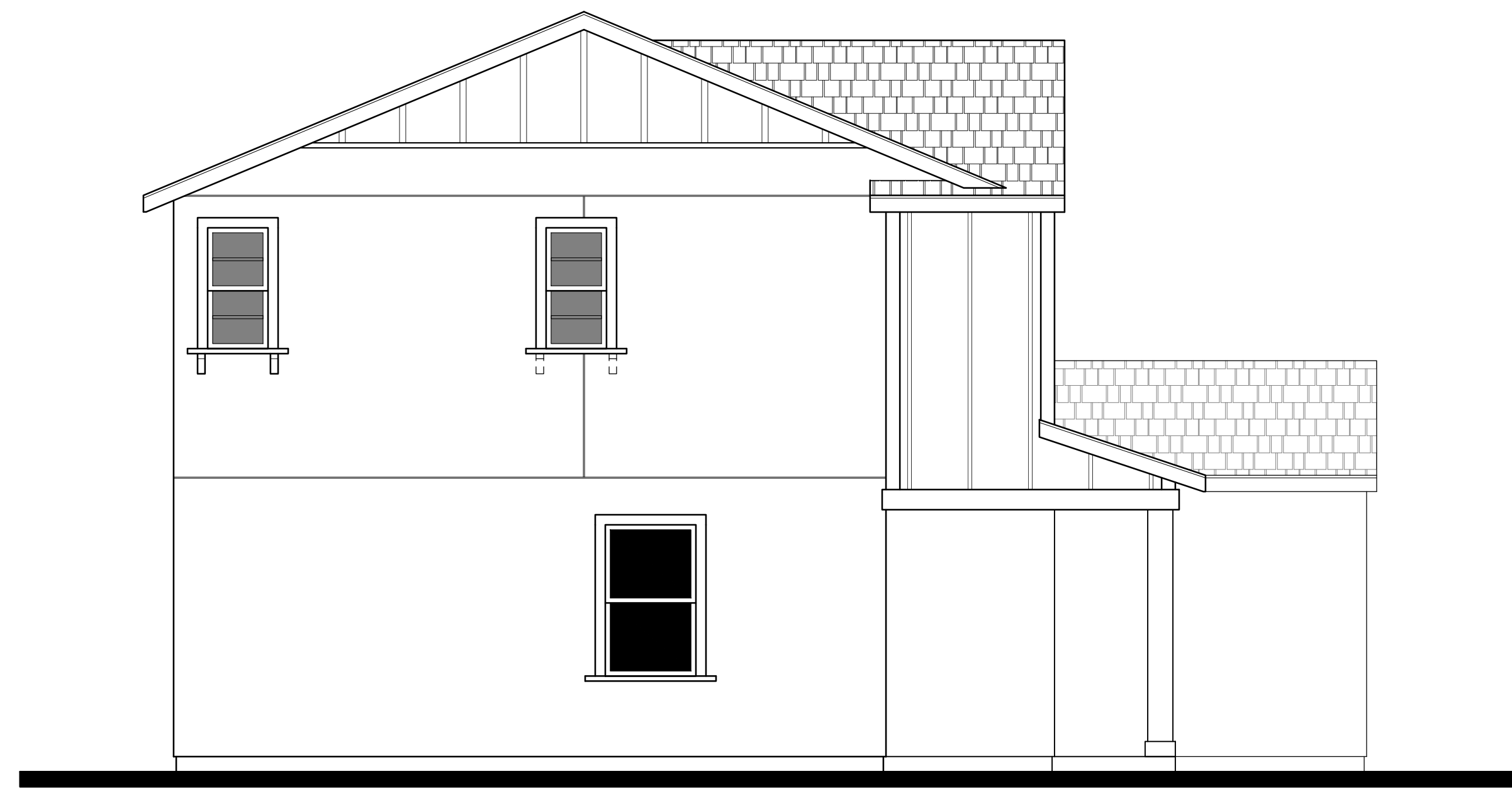

LEFT



FRONT

B - FARMHOUSE
1/4"=1'-0"

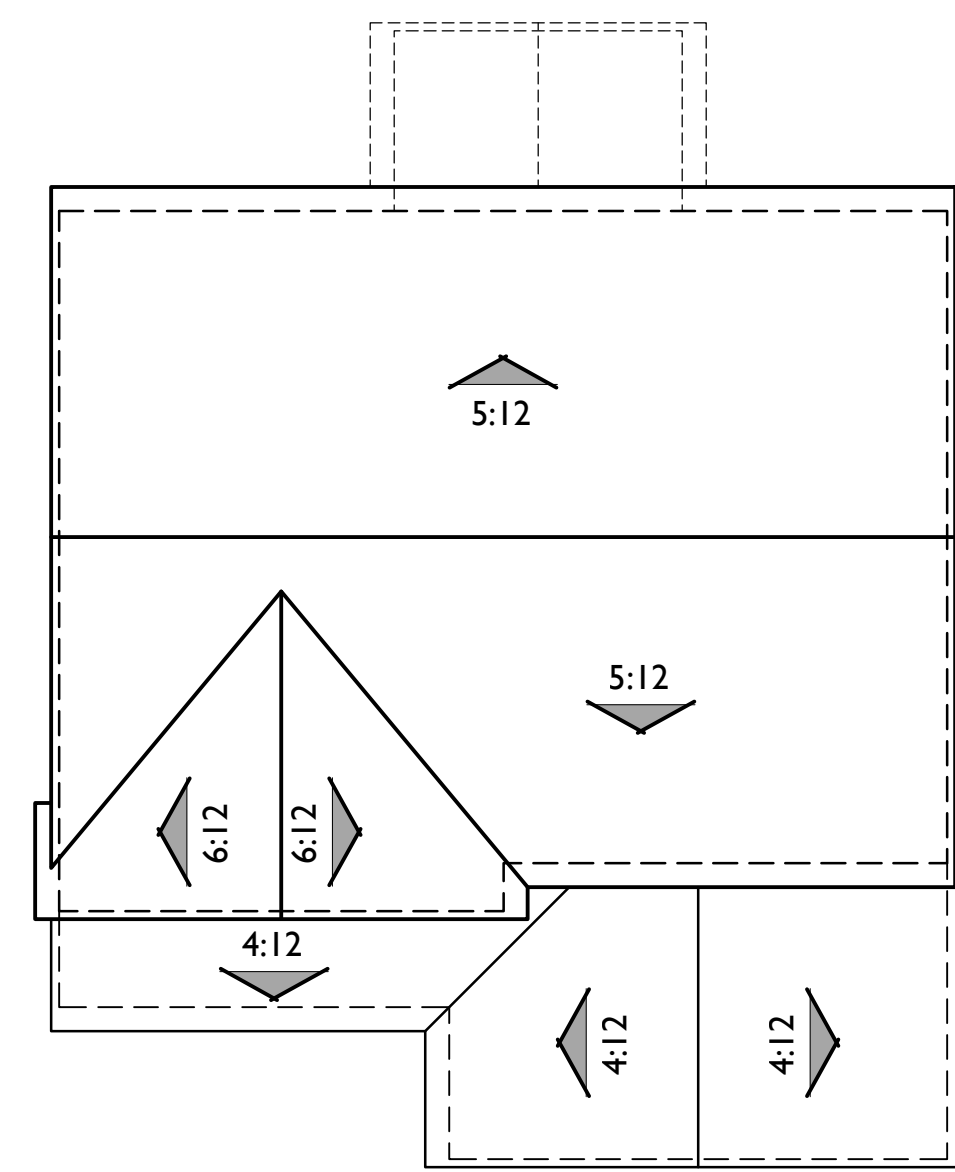

ROOF PLAN B

PITCH: 5:12 U.N.O.
RAKE: 4"
EAVE: 12"
ROOF MATERIAL: CONCRETE FLAT TILE

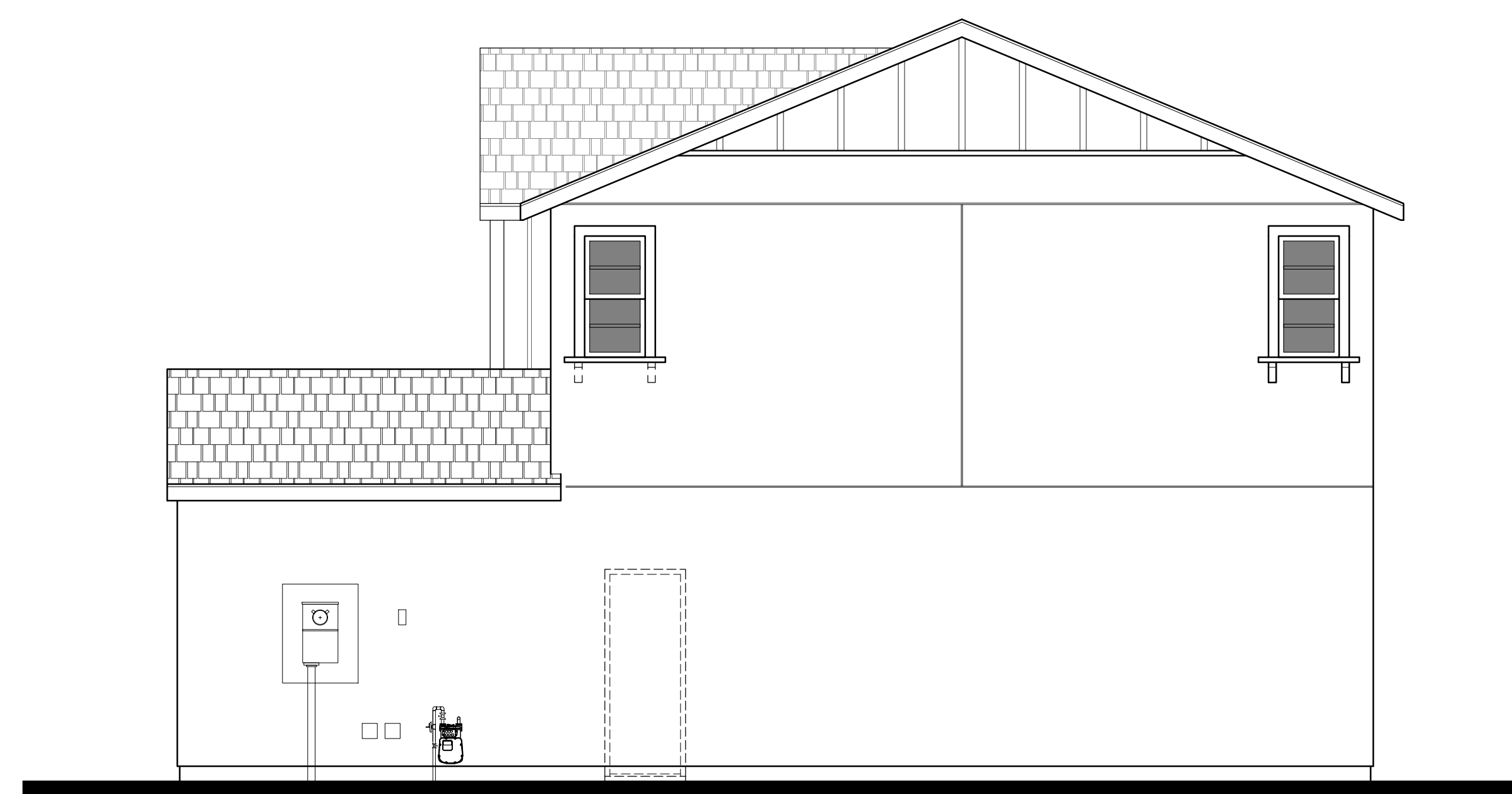

RIGHT

DASHED ENHANCEMENTS AT LOTS VISIBLE TO PUBLIC WALKWAYS, DRIVES AND PARKS. PLEASE VERIFY PER CIVIL PLOT PLAN.

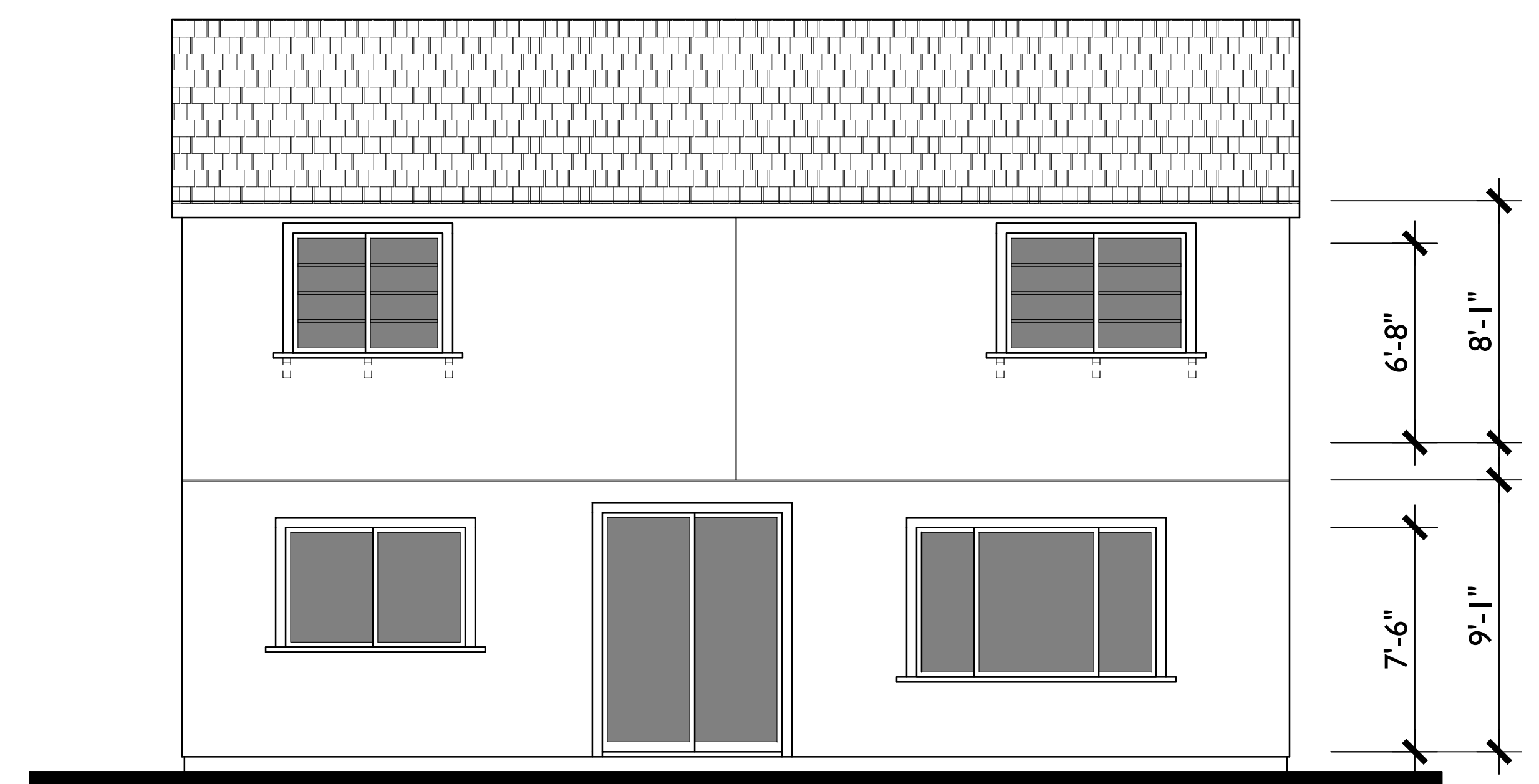

REAR

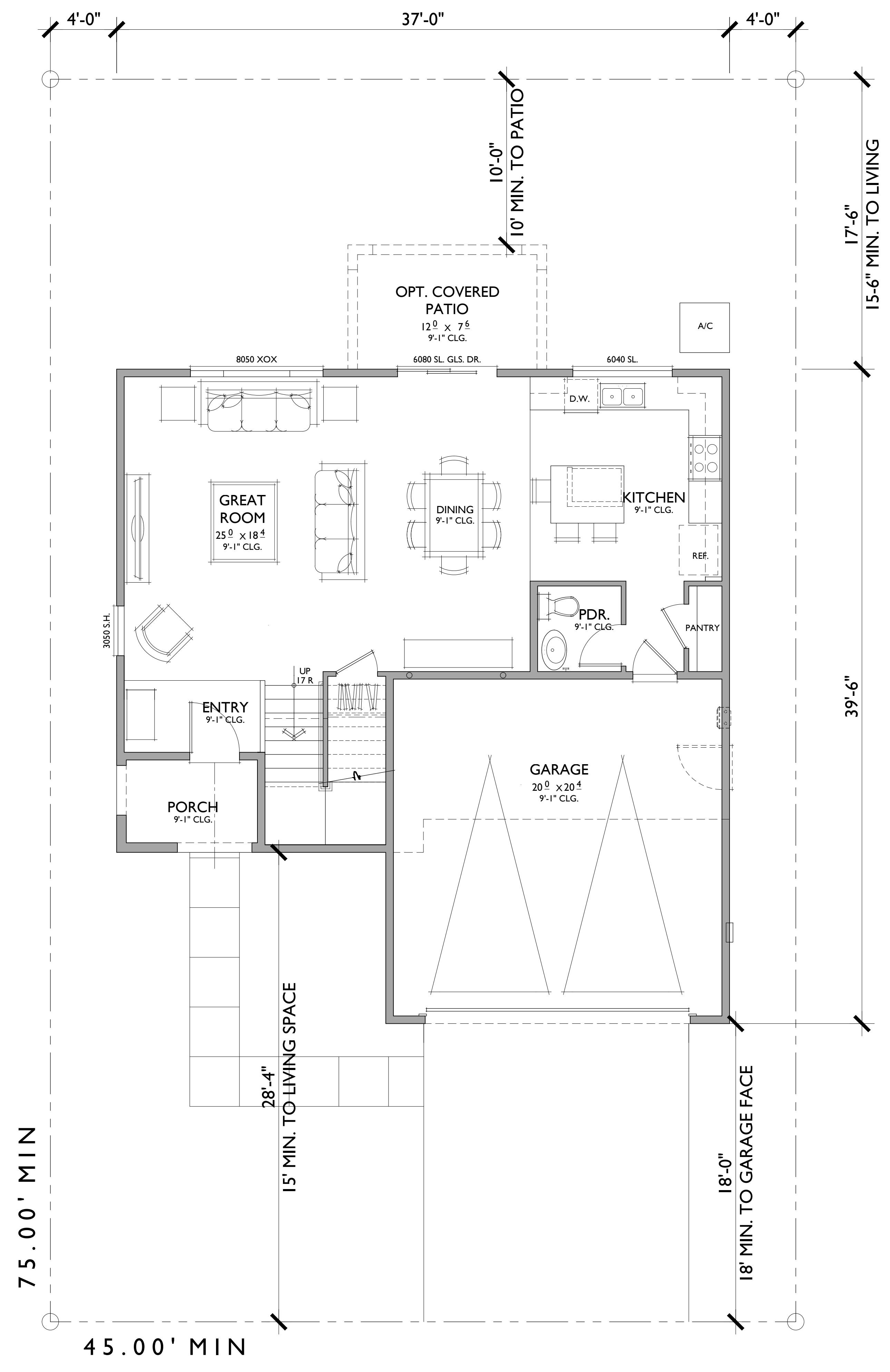
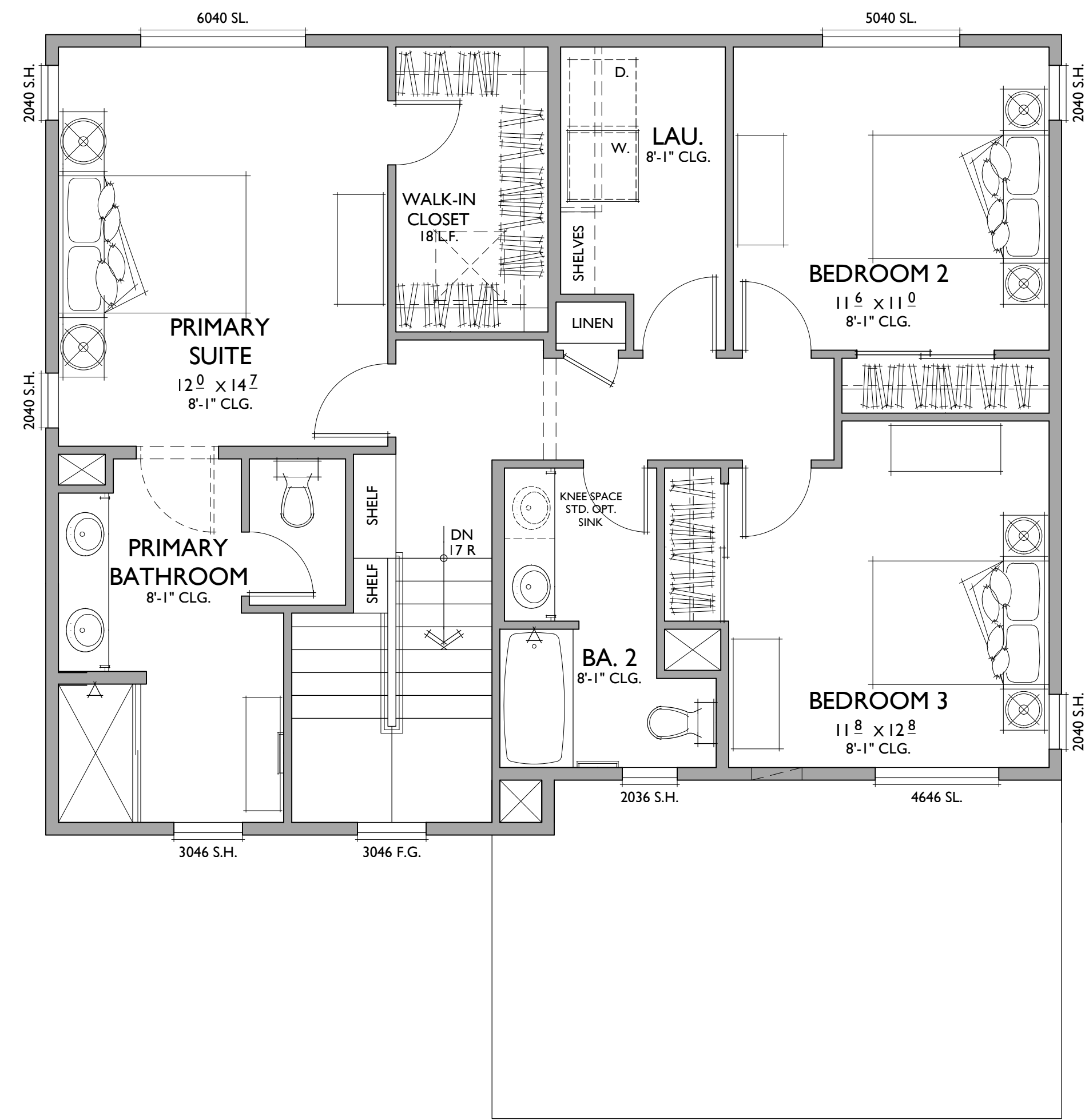

PLAN IC
1,786 SQ. FT.
 TARGET: 1,750 SQ. FT.
 3 BEDROOMS / 2.5 BATHS
 2 - CAR GARAGE

FLOOR AREA TABLE	
1ST FLOOR	818 SQ. FT.
2ND FLOOR	969 SQ. FT.
TOTAL LIVING	1,786 SQ. FT.
2 - CAR GARAGE	428 SQ. FT.
PORCH	47 SQ. FT.
OPT. COVERED PATIO	90 SQ. FT.

NOTE: SQUARE FOOTAGE MAY VARY DUE TO METHOD OF CALCULATION

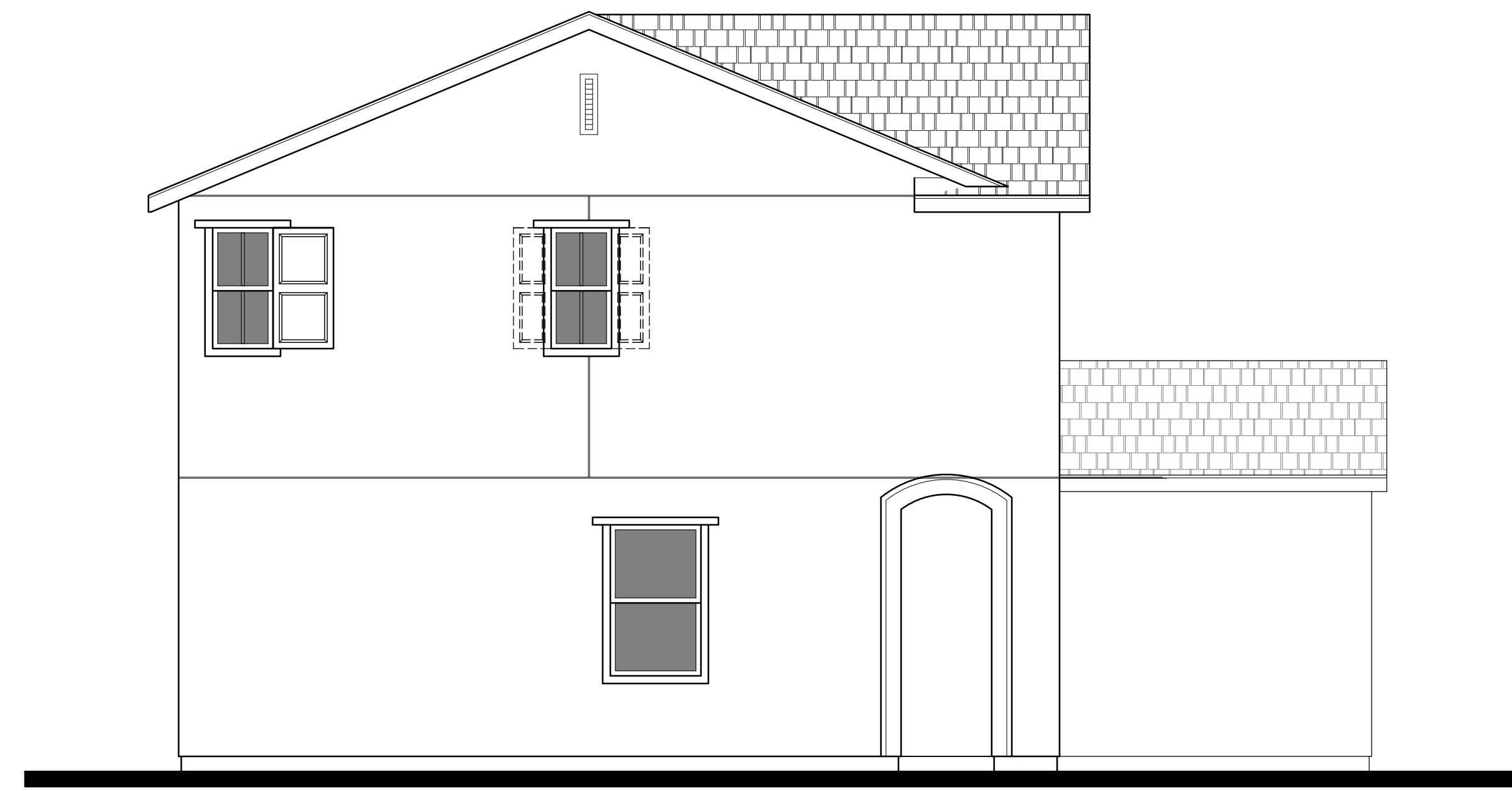

LEFT



FRONT

C - COTTAGE
1/4"=1'-0"

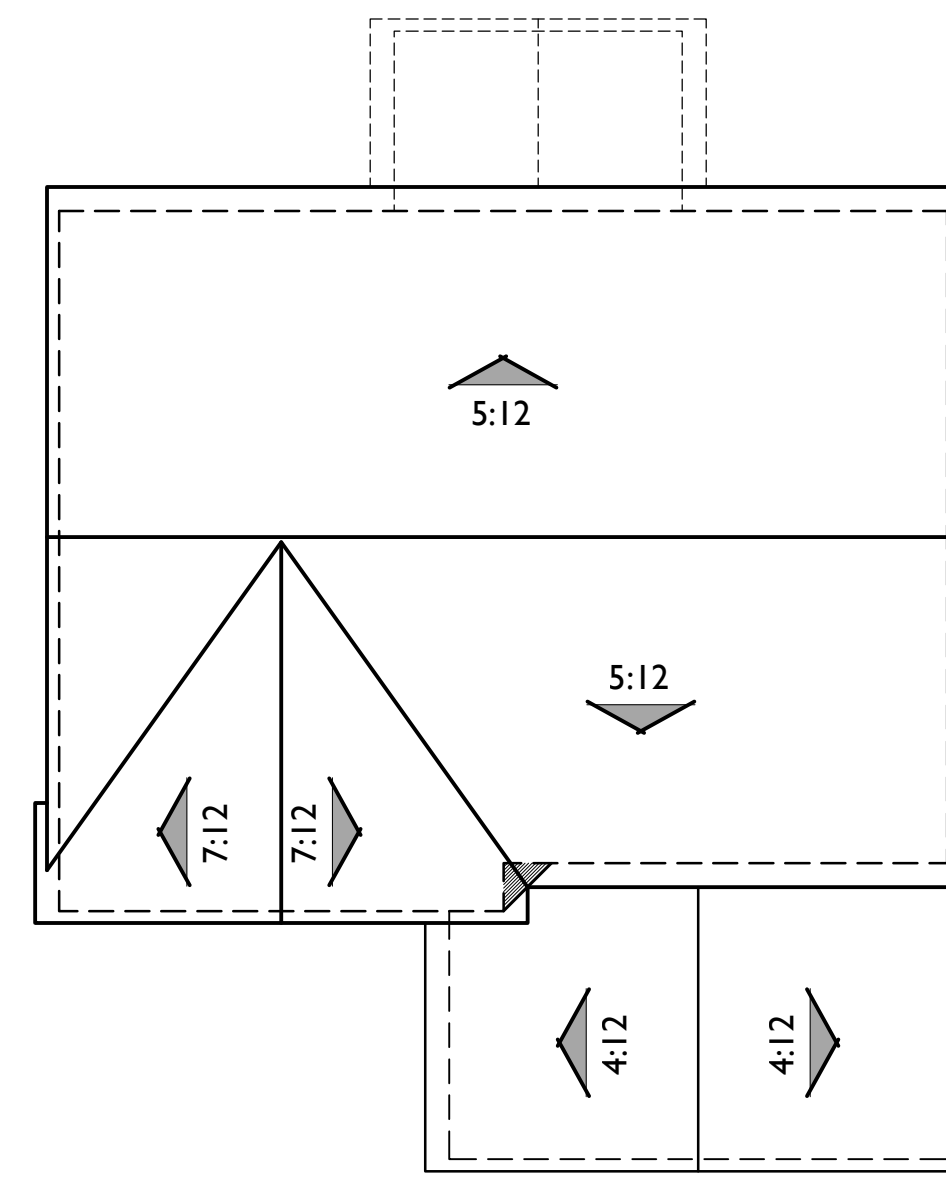

ROOF PLAN C

PITCH: 5:12 U.N.O.
RAKE: 6"
EAVE: 12"
ROOF MATERIAL: CONCRETE FLAT TILE

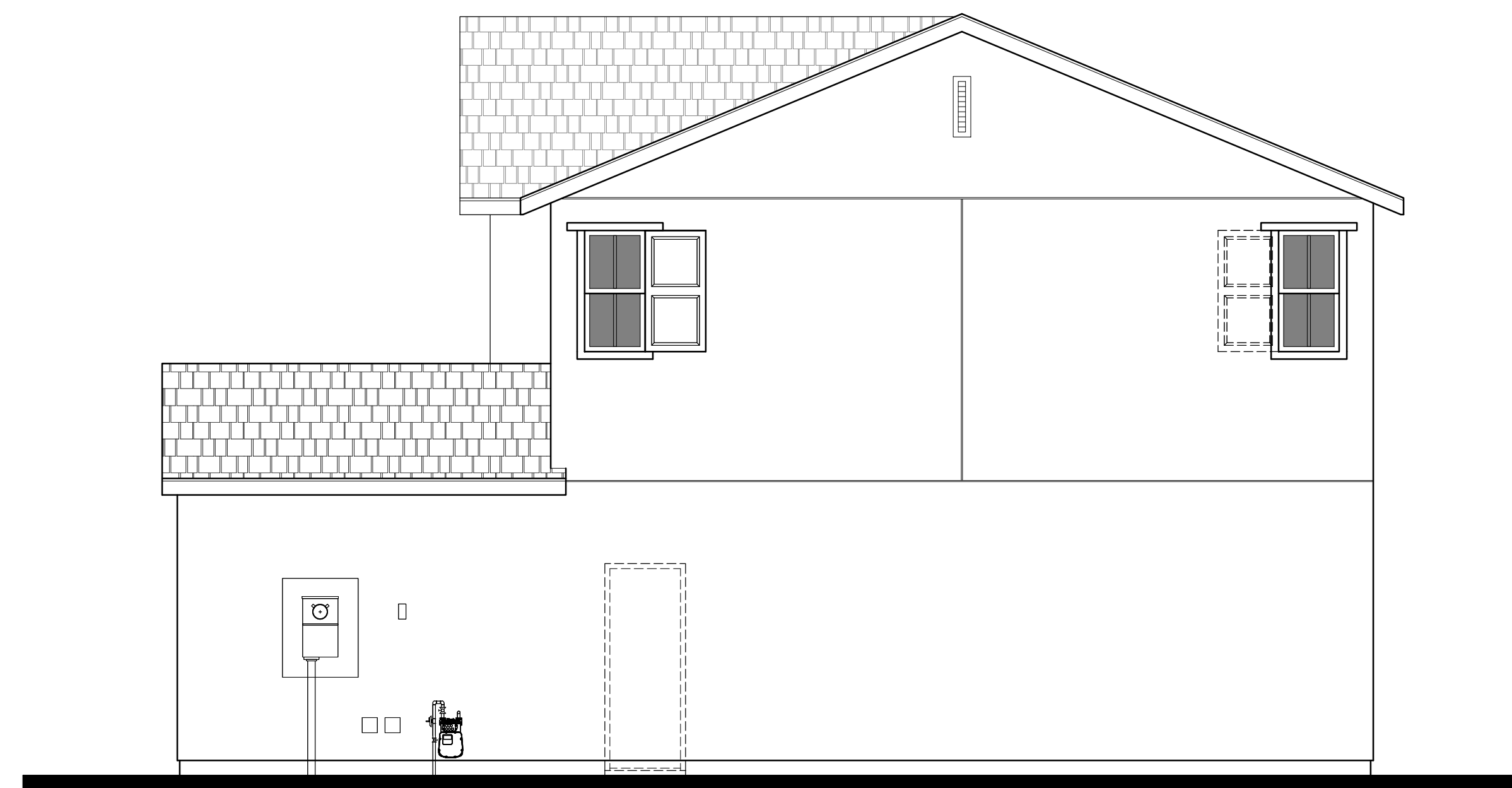

RIGHT

DASHED ENHANCEMENTS AT LOTS VISIBLE TO PUBLIC WALKWAYS, DRIVES AND PARKS. PLEASE VERIFY PER CIVIL PLOT PLAN.

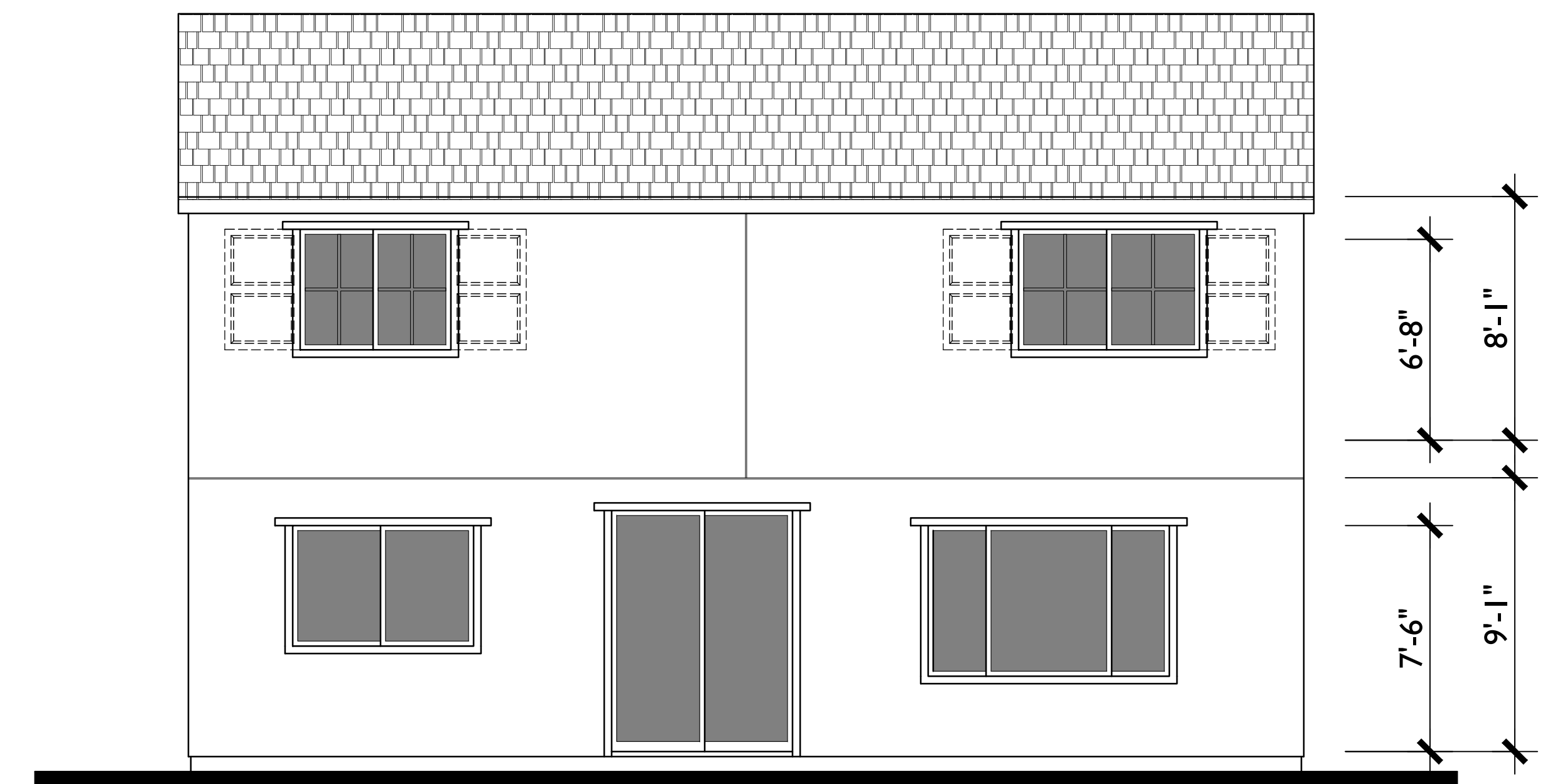

REAR

ELEVATIONS

THREE ELEVATION THEMES HAVE BEEN SELECTED FOR THIS COMMUNITY: TRANSITIONAL RANCH, FARMHOUSE AND COTTAGE. THE STYLES, ALTHOUGH DIFFERENT, ARE HARMONIOUS IN THAT THEY SHARE A COMMON AGRICULTURAL HERITAGE REINTERPRETED TO CREATE A LASTING CONTRIBUTION TO THE COMMUNITY. THIS IS ACHIEVED THROUGH APPROPRIATE USES OF EXTERIOR MATERIAL, ARTICULATION OF ENTRY DETAILS (ARCHES, POSTS, AND PORCHES) ALONG WITH VARYING ROOF PITCHES SPECIFIC TO EACH STYLE.

TRANSITIONAL RANCH

THE TRANSITIONAL RANCH USES A LOW ROOF PITCH AND HAS GABLE END ACCENTS, SHUTTERS, AND POTSHelves AT SELECT LOCATIONS.

FARMHOUSE

THE FARMHOUSE IS A CLASSIC STYLE USING STEEP ROOF PITCHES ALONG WITH BOARD AND BATTEN ACCENTS AND APPROPRIATELY THEMED LIGHTING.

COTTAGE

THE COTTAGE ALSO HAS STEEP ACCENT ROOFS AND HANDSOME SHUTTERS TO ACCENT THE WINDOWS AND IN THE CASE OF PLANS 1 AND 3 HAVE A GRACEFUL SOFT ARCH TO HIGHLIGHT THE ENTRY.

THEME SPECIFIC COACH LIGHTS, FRONT DOORS AND GARAGE DOORS ADD THE FINISHING TOUCHES TO THIS PLAN SERIES.

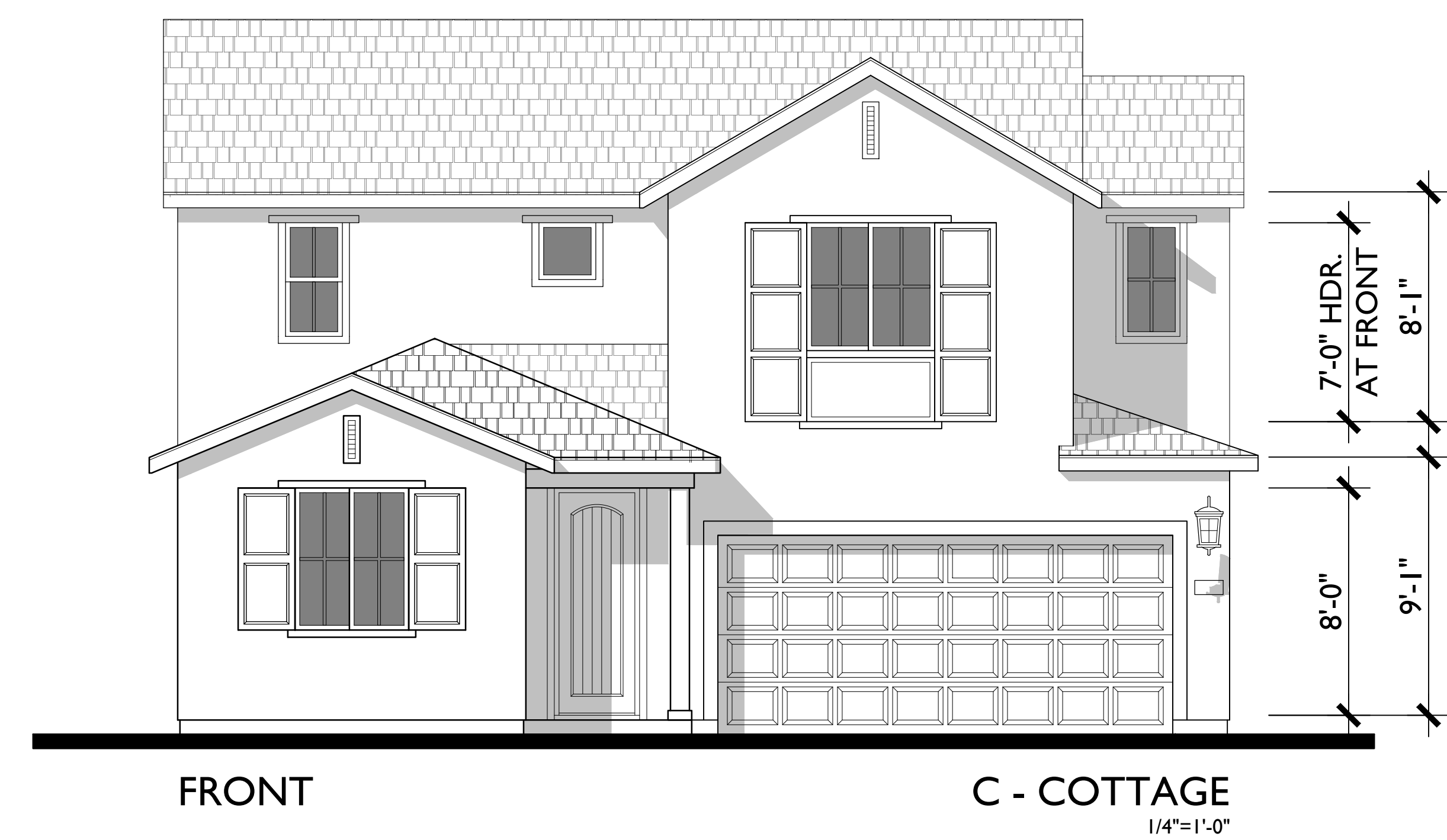
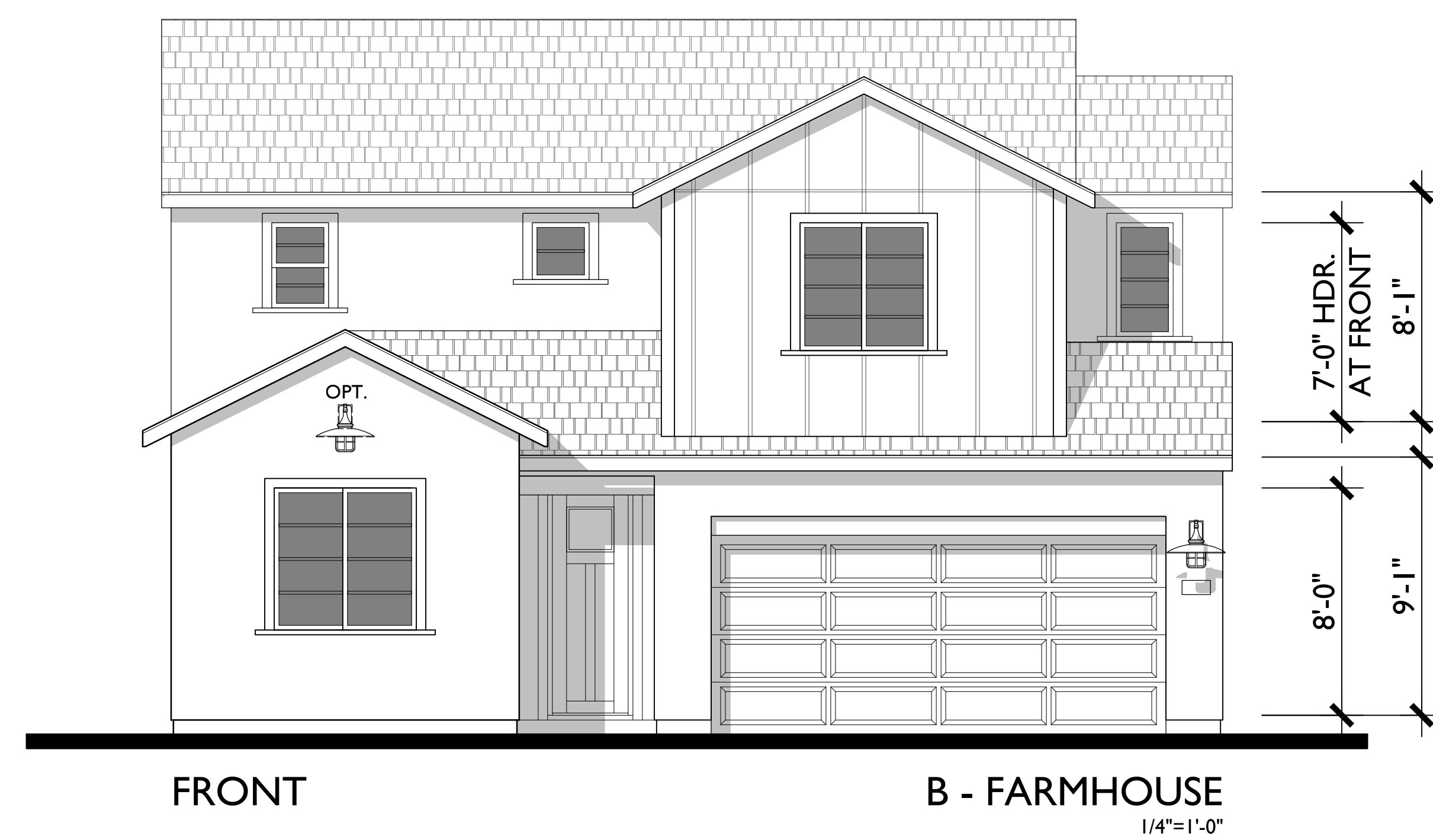
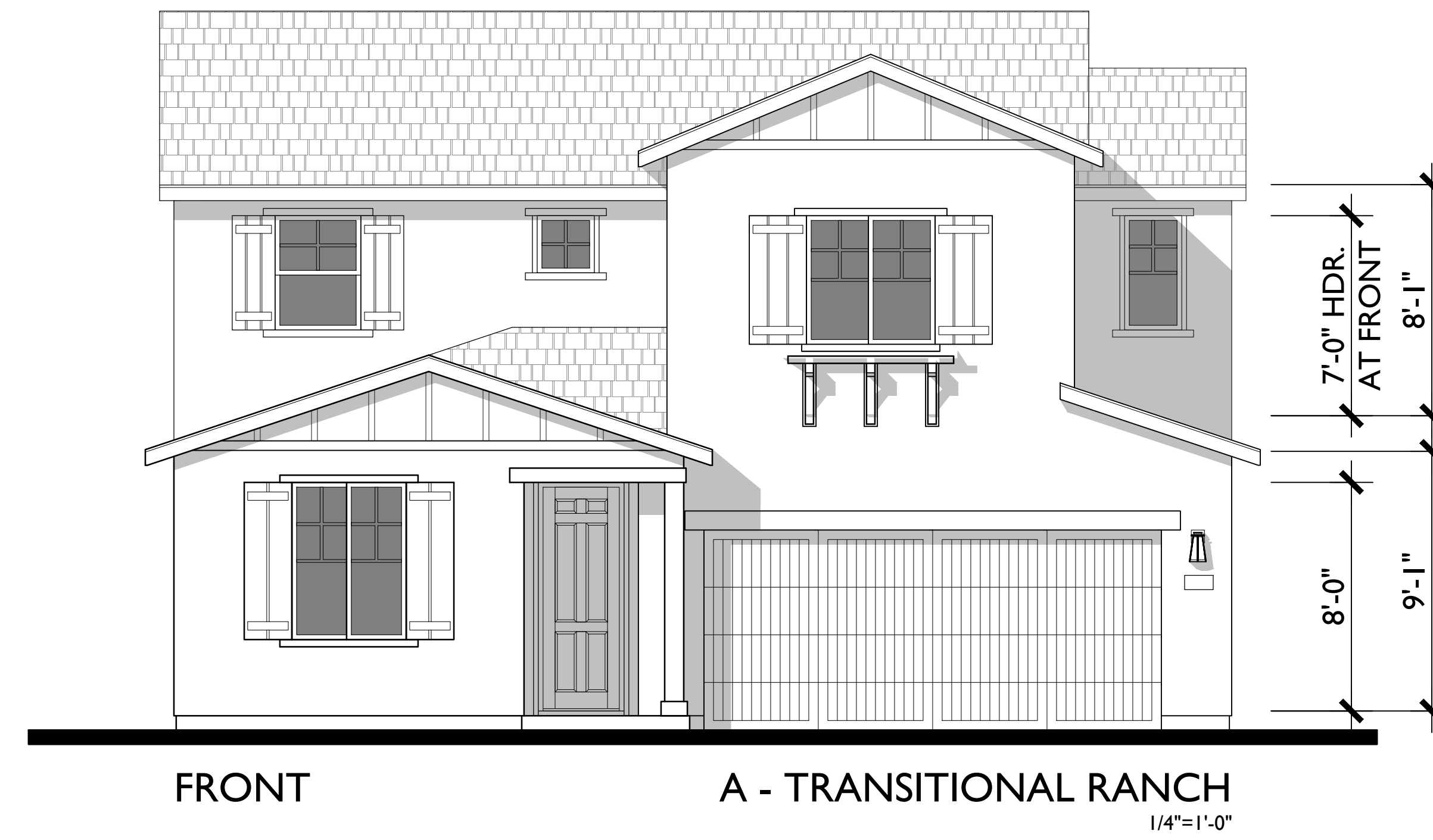

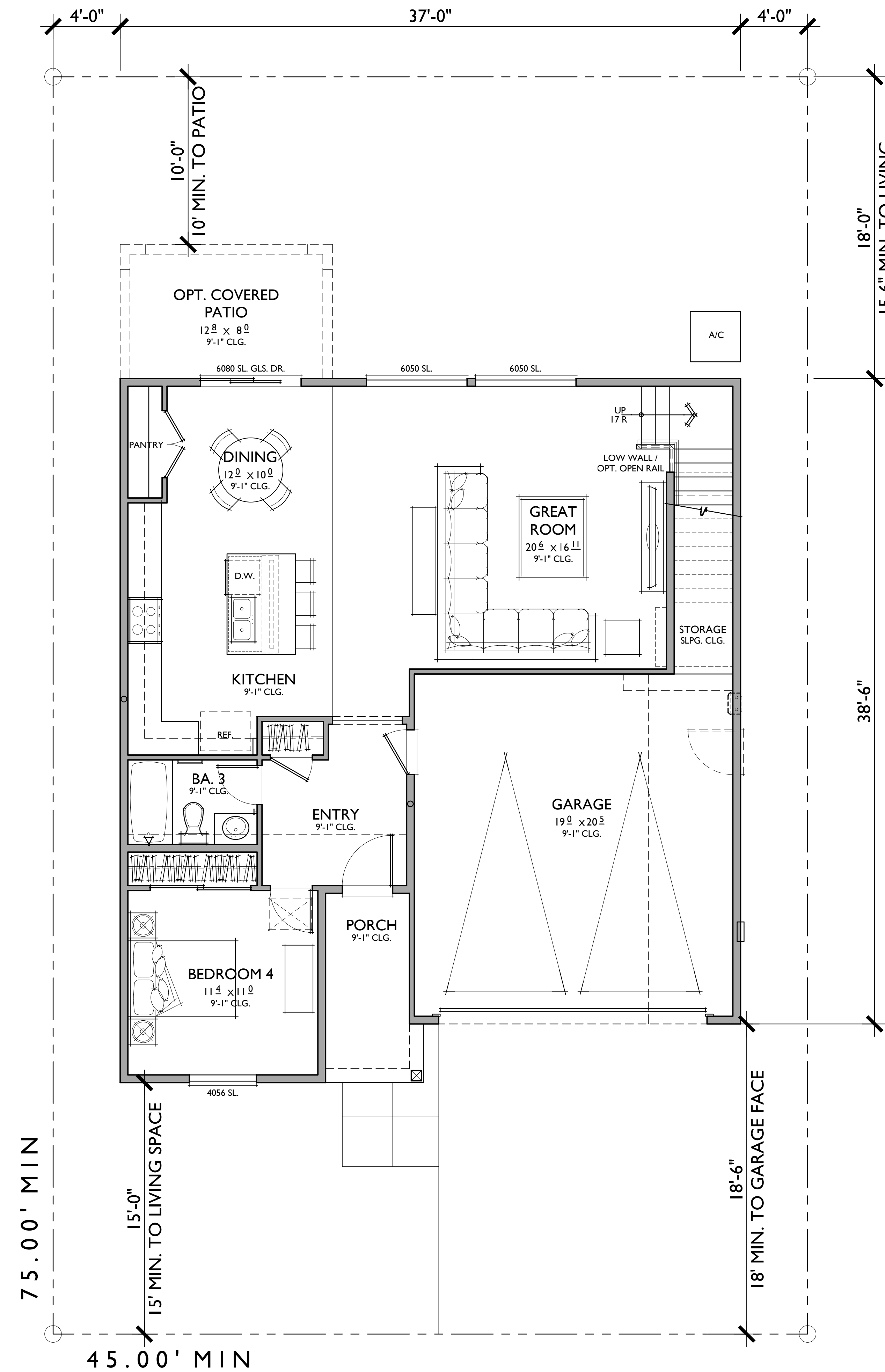
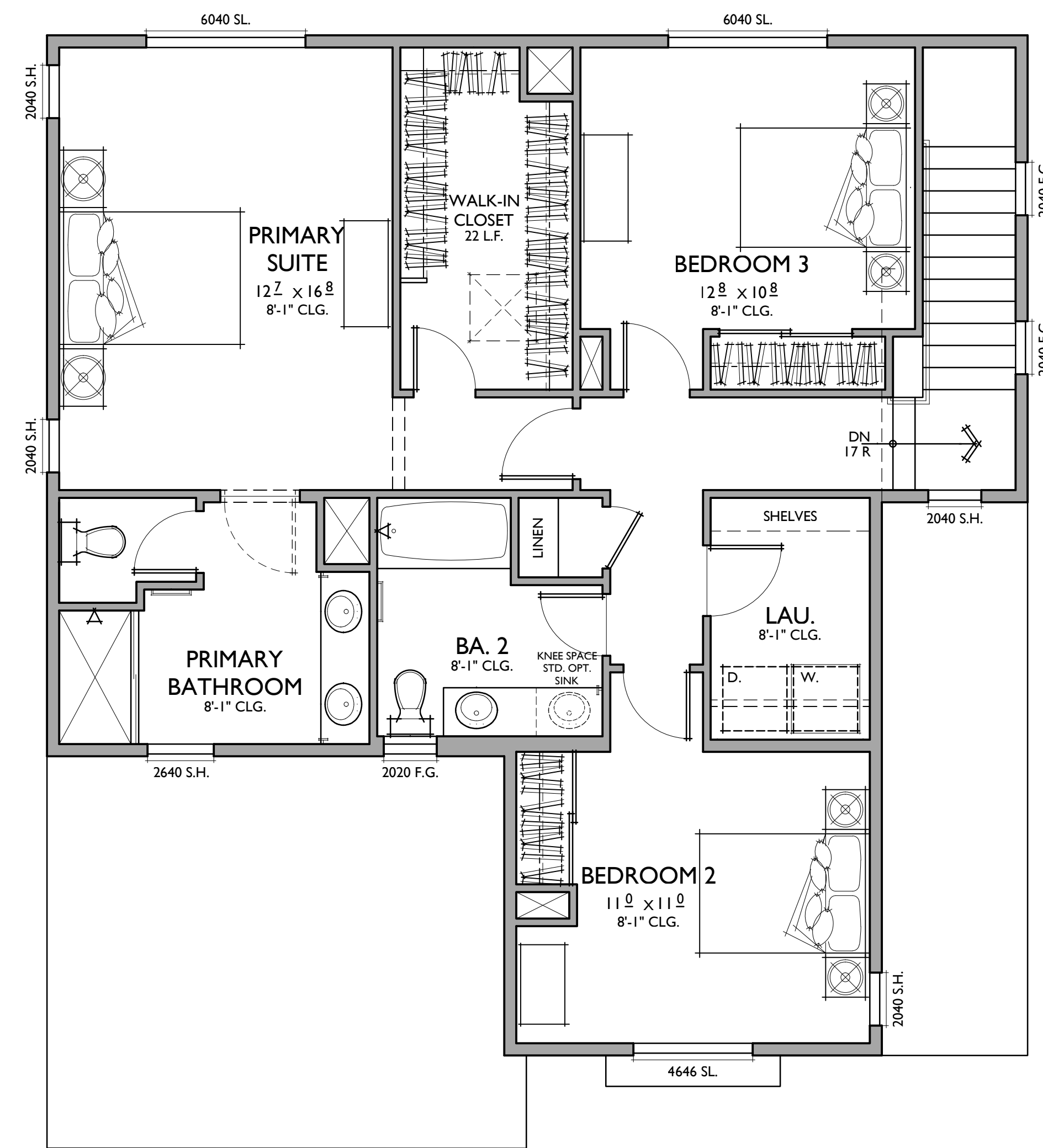

PLAN 2A
2,058 SQ. FT.
 TARGET: 1,950 SQ. FT.
 4 BEDROOMS / 3 BATHS
 2 - CAR GARAGE

FLOOR AREA TABLE	
1ST FLOOR	1020 SQ. FT.
2ND FLOOR	1038 SQ. FT.
TOTAL LIVING	2,058 SQ. FT.
2 - CAR GARAGE	451 SQ. FT.
PORCH	59 SQ. FT.
OPT. COVERED PATIO	101 SQ. FT.

NOTE: SQUARE FOOTAGE MAY VARY DUE TO METHOD OF CALCULATION

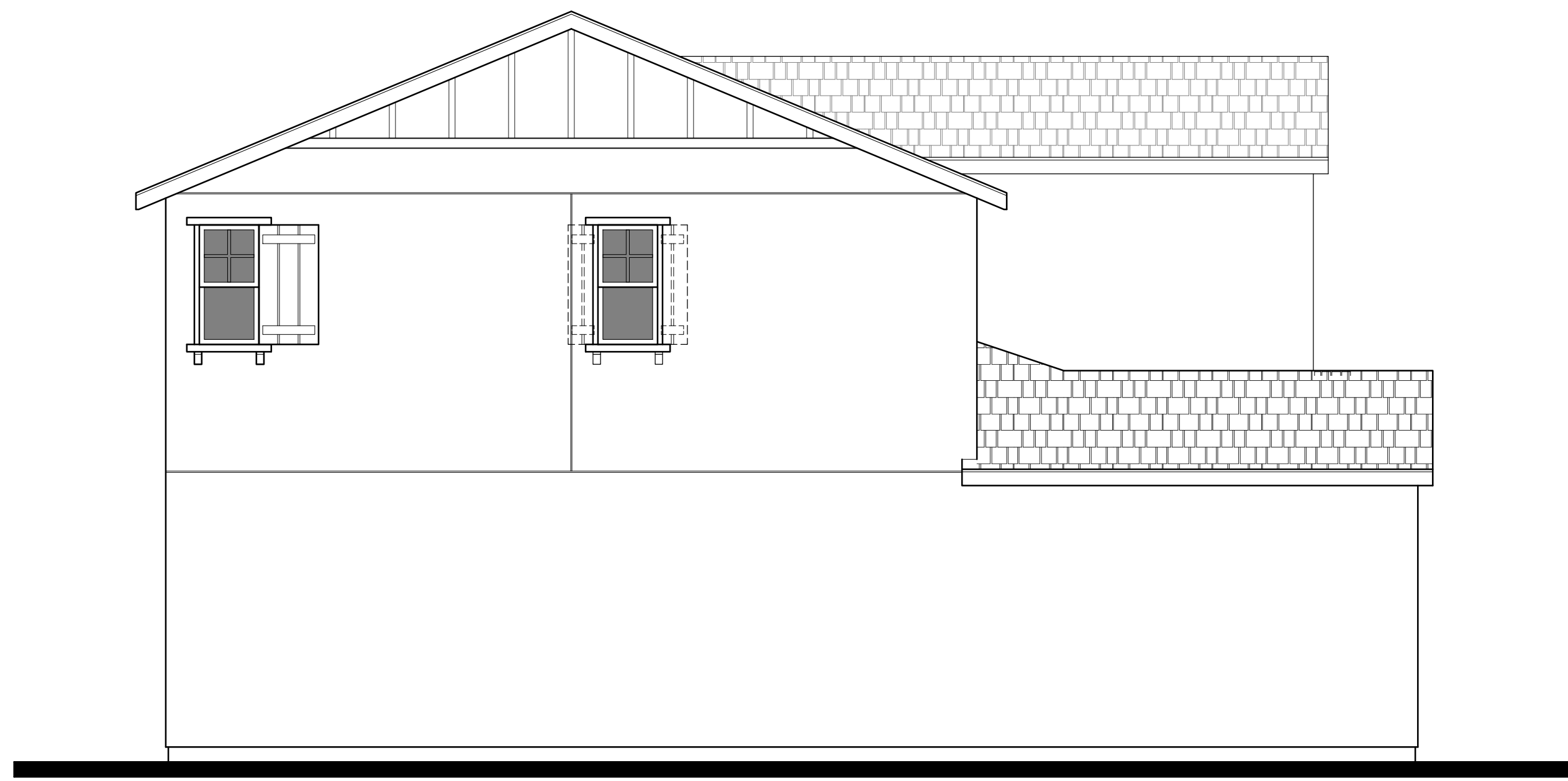

LEFT



FRONT

A - TRANSITIONAL RANCH
1/4"=1'-0"

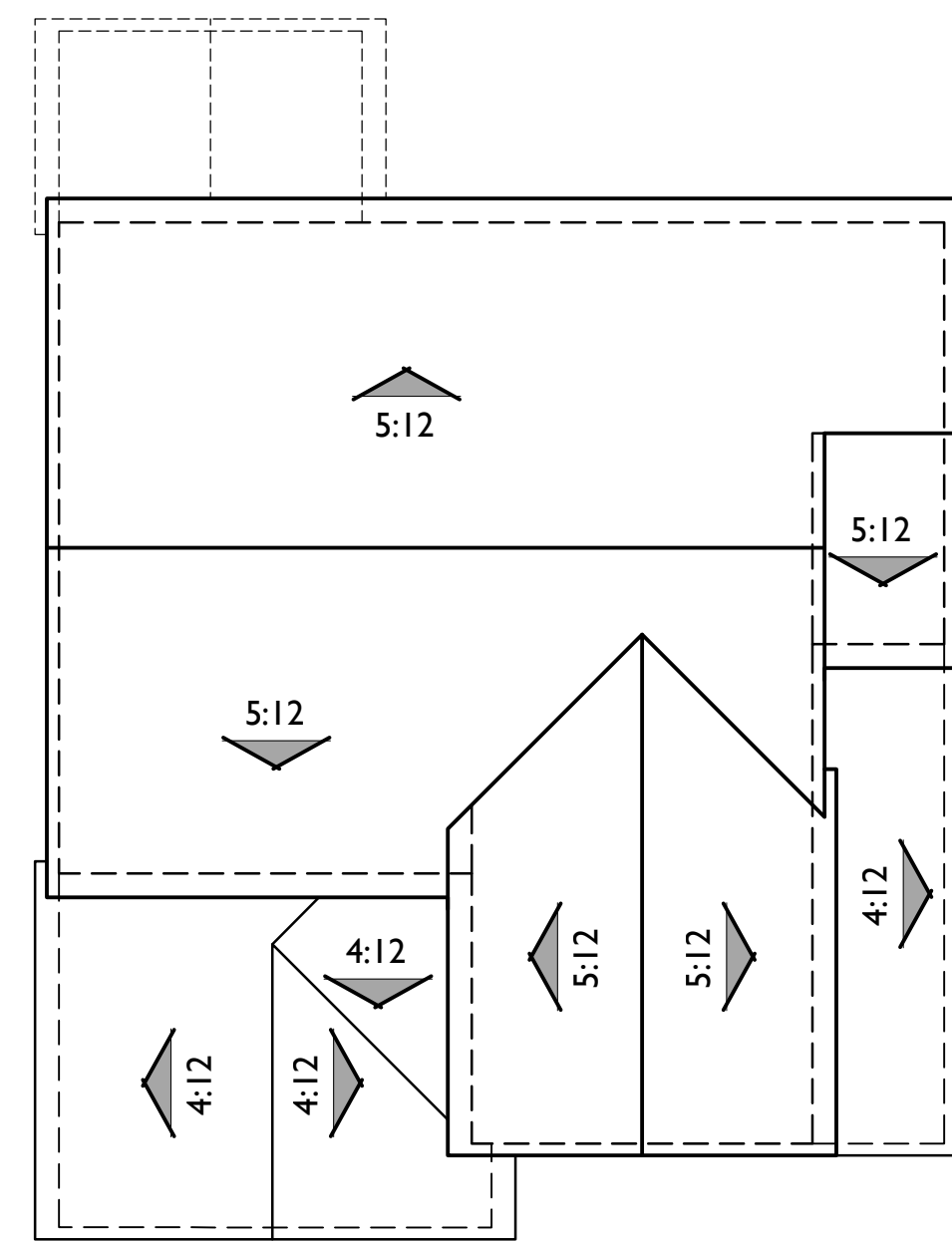

ROOF PLAN A
PITCH: 5:12 U.N.O.
RAKE: 6"
EAVE: 12"
ROOF MATERIAL: CONCRETE FLAT TILE



RIGHT

DASHED ENHANCEMENTS AT LOTS VISIBLE TO PUBLIC WALKWAYS, DRIVES AND PARKS. PLEASE VERIFY PER CIVIL PLOT PLAN.

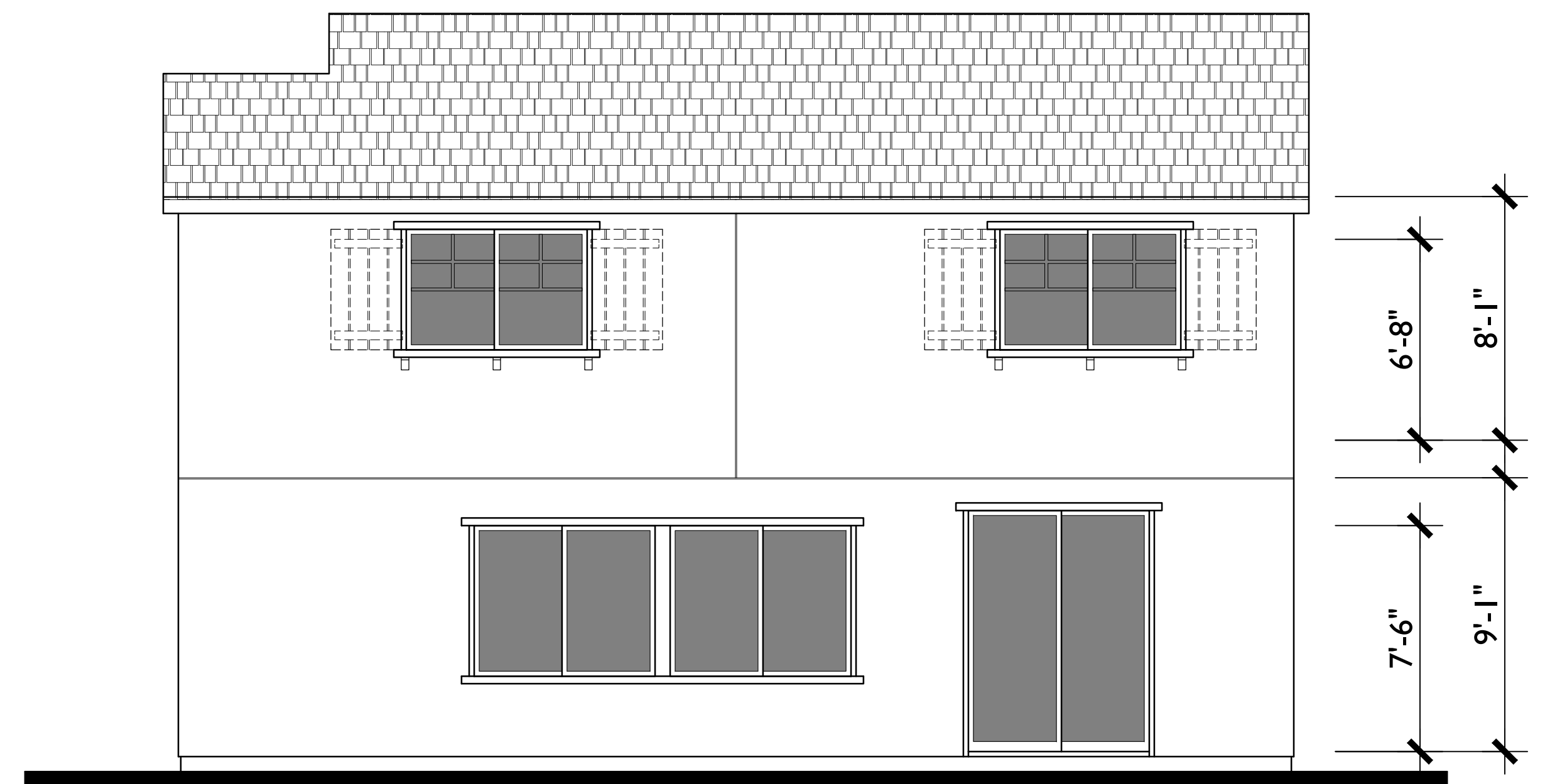

REAR

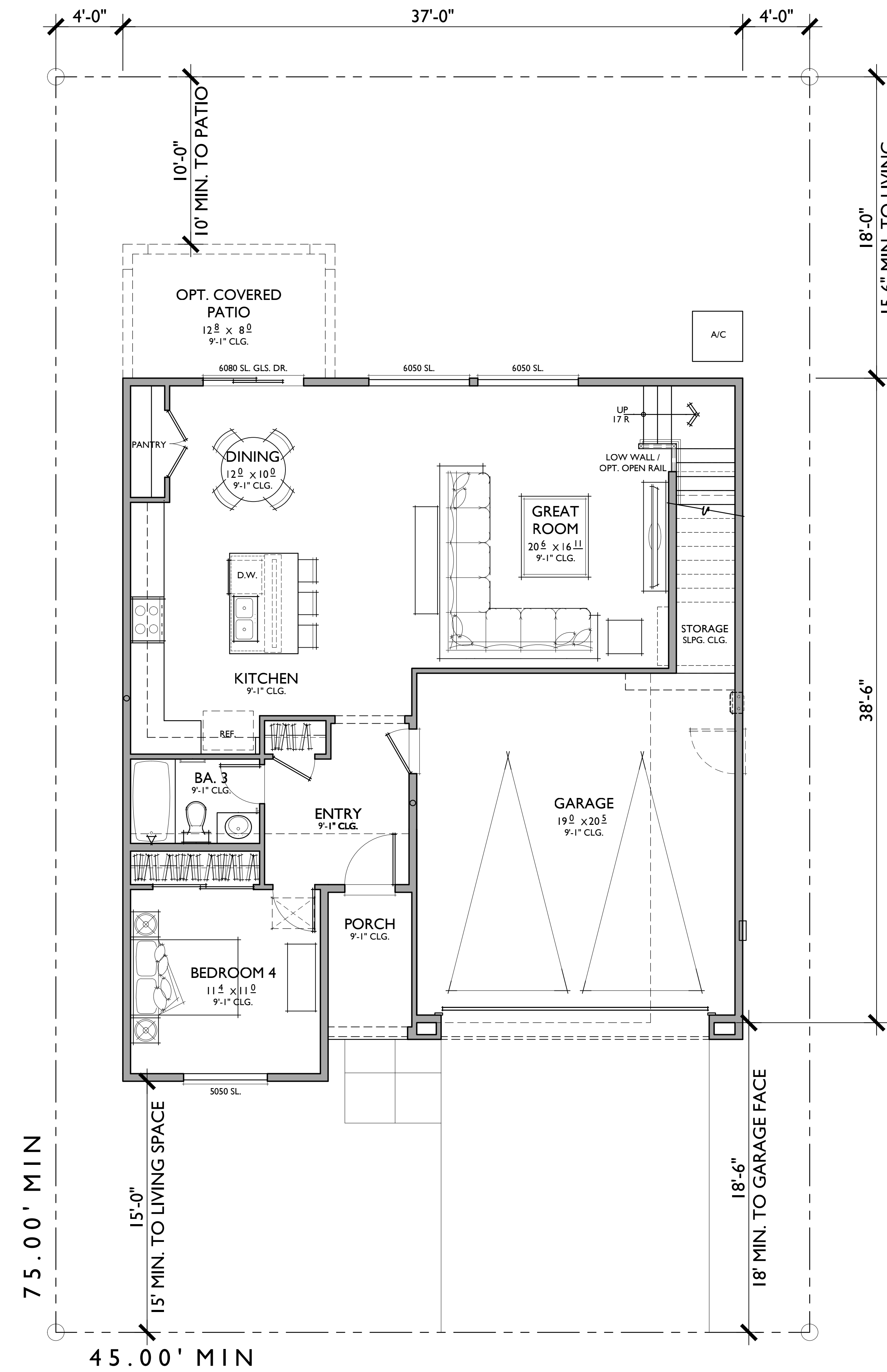
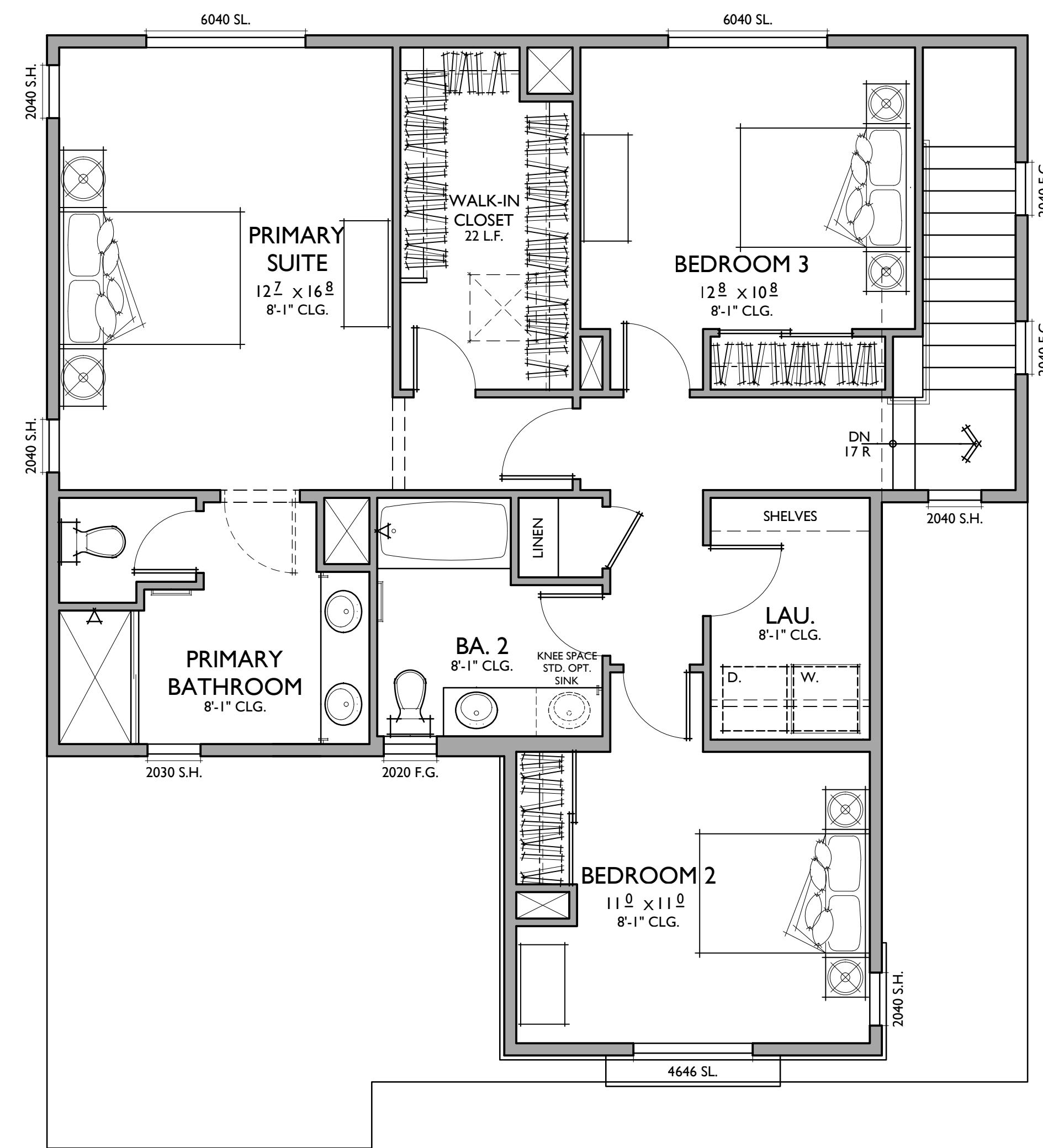

PLAN 2B
2,058 SQ. FT.
 TARGET: 1,950 SQ. FT.
 4 BEDROOMS / 3 BATHS
 2 - CAR GARAGE

FLOOR AREA TABLE	
1ST FLOOR	1020 SQ. FT.
2ND FLOOR	1038 SQ. FT.
TOTAL LIVING	2,058 SQ. FT.
2 - CAR GARAGE	462 SQ. FT.
PORCH	44 SQ. FT.
OPT. COVERED PATIO	101 SQ. FT.

NOTE: SQUARE FOOTAGE MAY VARY DUE TO METHOD OF CALCULATION

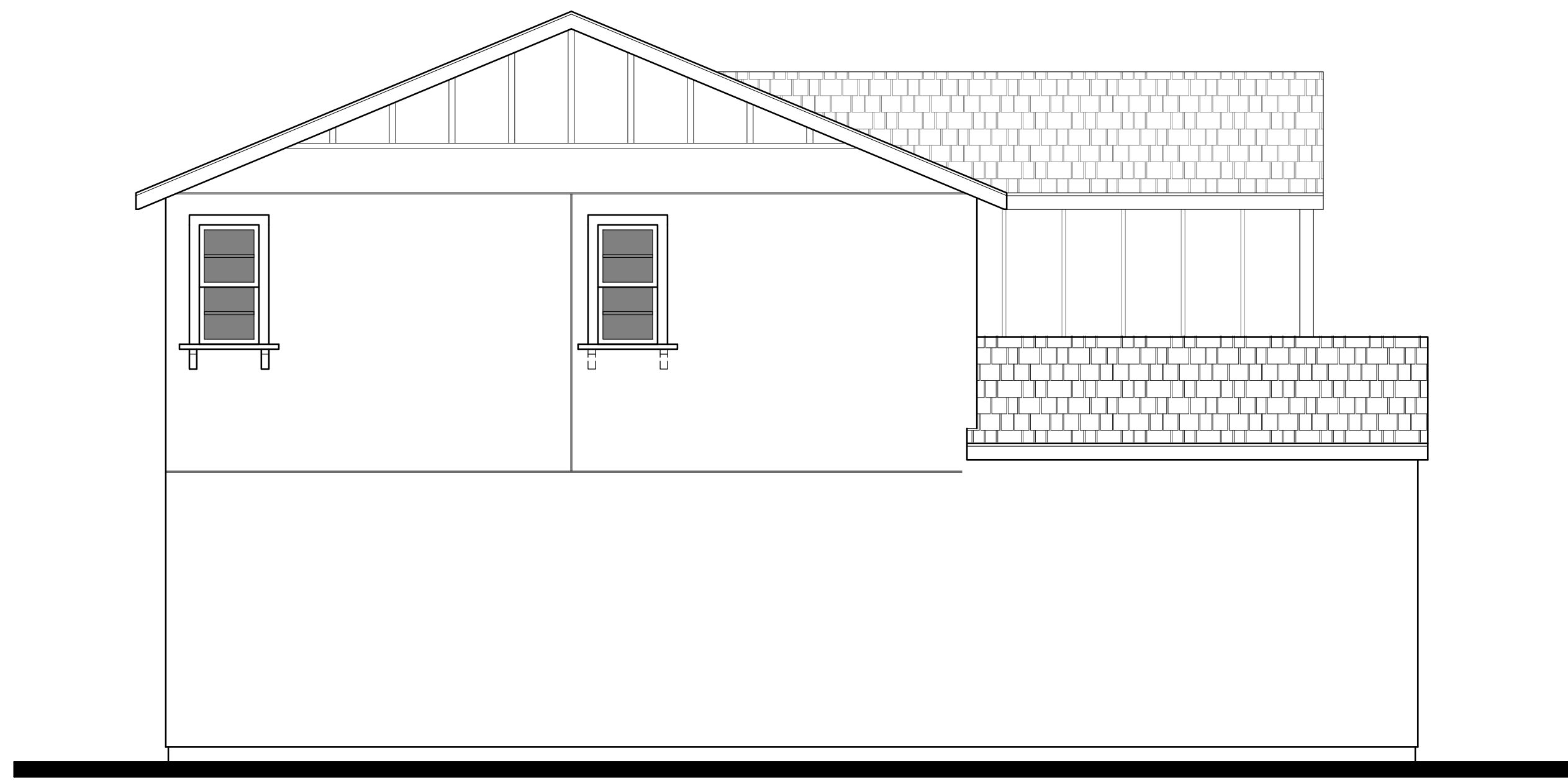

LEFT



FRONT

B - FARMHOUSE
1/4"=1'-0"

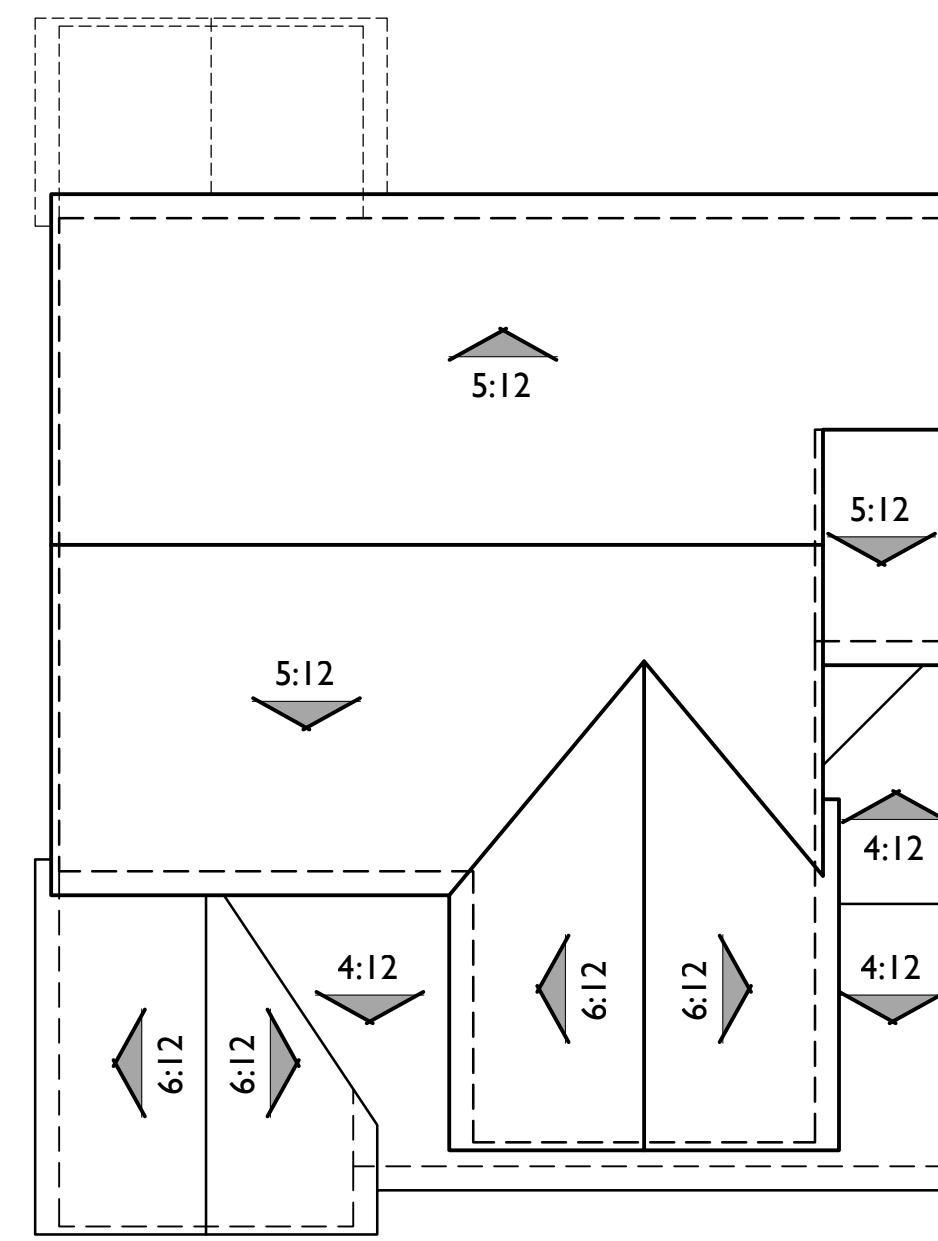

ROOF PLAN B
PITCH: 5:12 U.N.O.
RAKE: 4"
EAVE: 12"
ROOF MATERIAL: CONCRETE FLAT TILE



RIGHT

DASHED ENHANCEMENTS AT LOTS VISIBLE TO PUBLIC WALKWAYS, DRIVES AND PARKS. PLEASE VERIFY PER CIVIL PLOT PLAN.

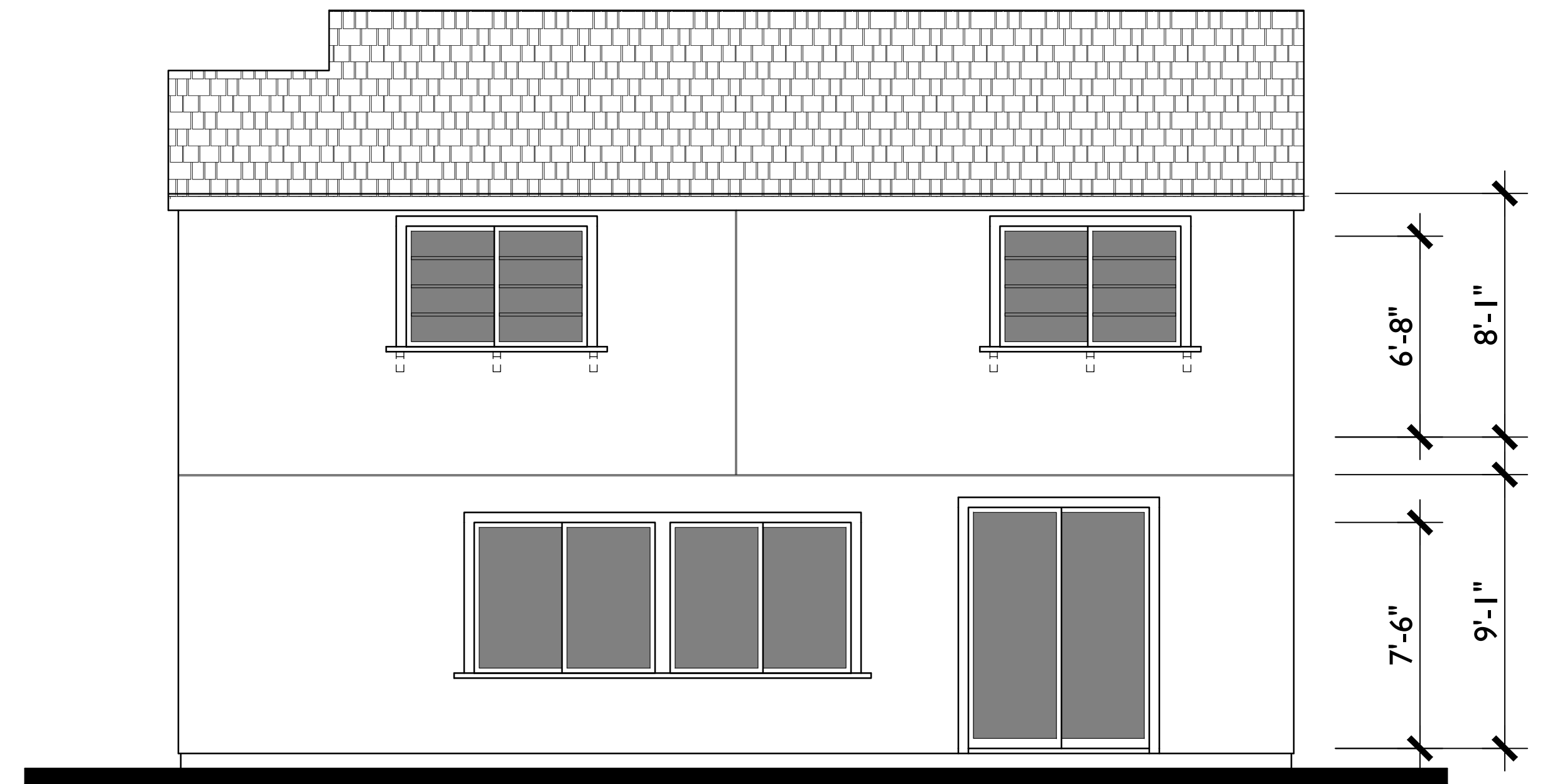

REAR

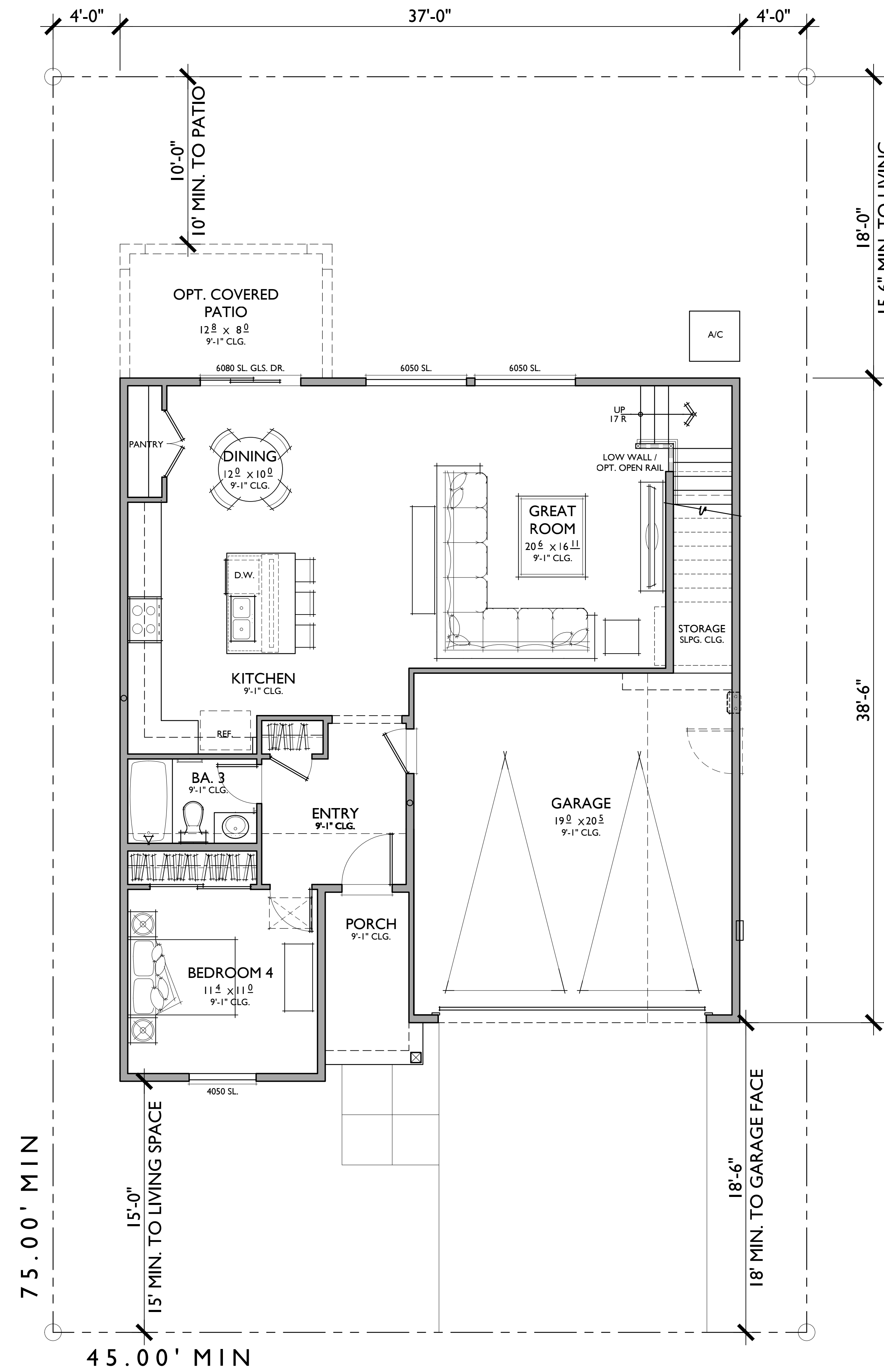
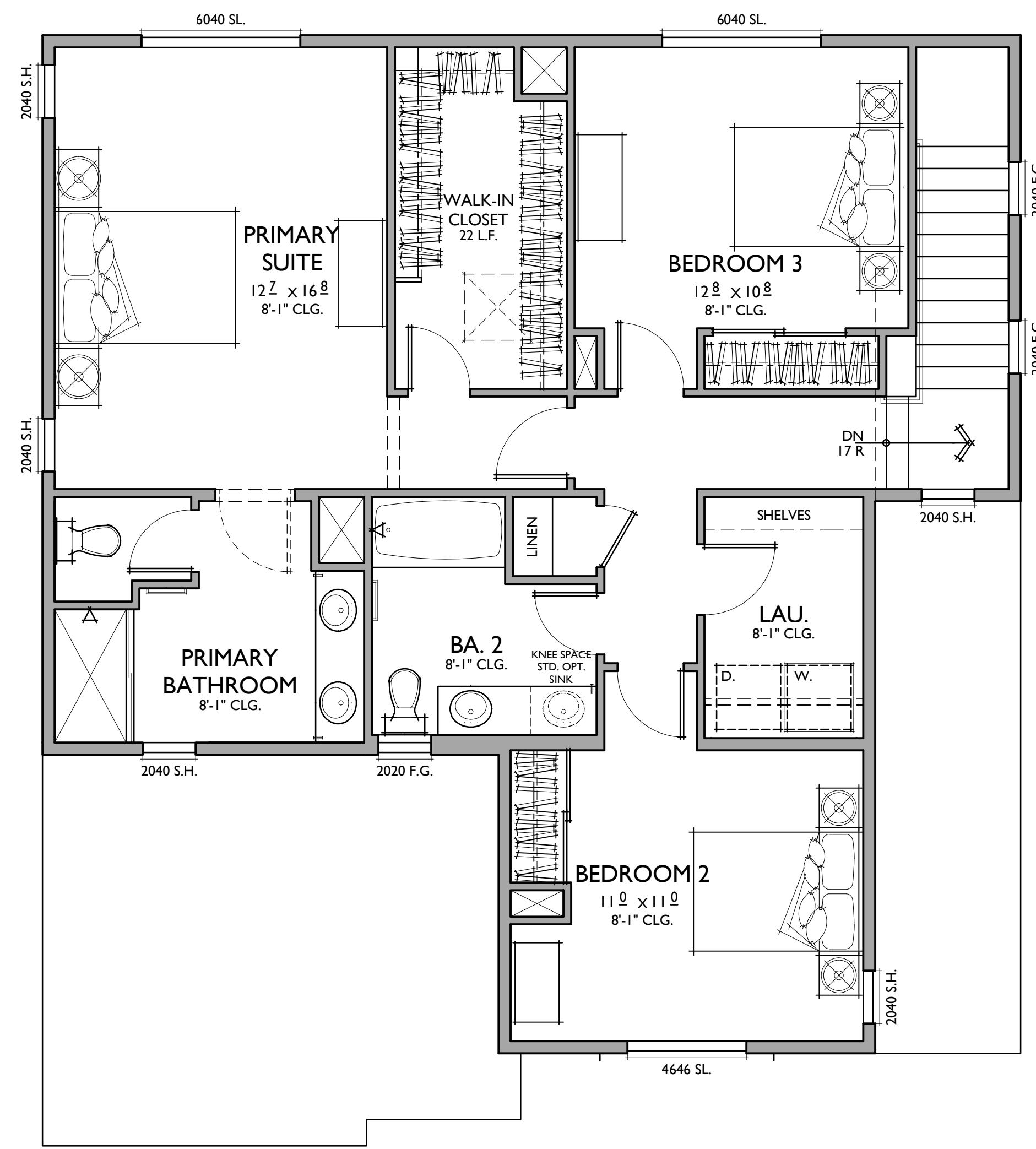

PLAN 2C
2,058 SQ. FT.
 TARGET: 1,950 SQ. FT.
 4 BEDROOMS / 3 BATHS
 2 - CAR GARAGE

FLOOR AREA TABLE	
1ST FLOOR	1020 SQ. FT.
2ND FLOOR	1038 SQ. FT.
TOTAL LIVING	2,058 SQ. FT.
2 - CAR GARAGE	462 SQ. FT.
PORCH	54 SQ. FT.
OPT. COVERED PATIO	101 SQ. FT.

NOTE: SQUARE FOOTAGE MAY VARY DUE TO METHOD OF CALCULATION

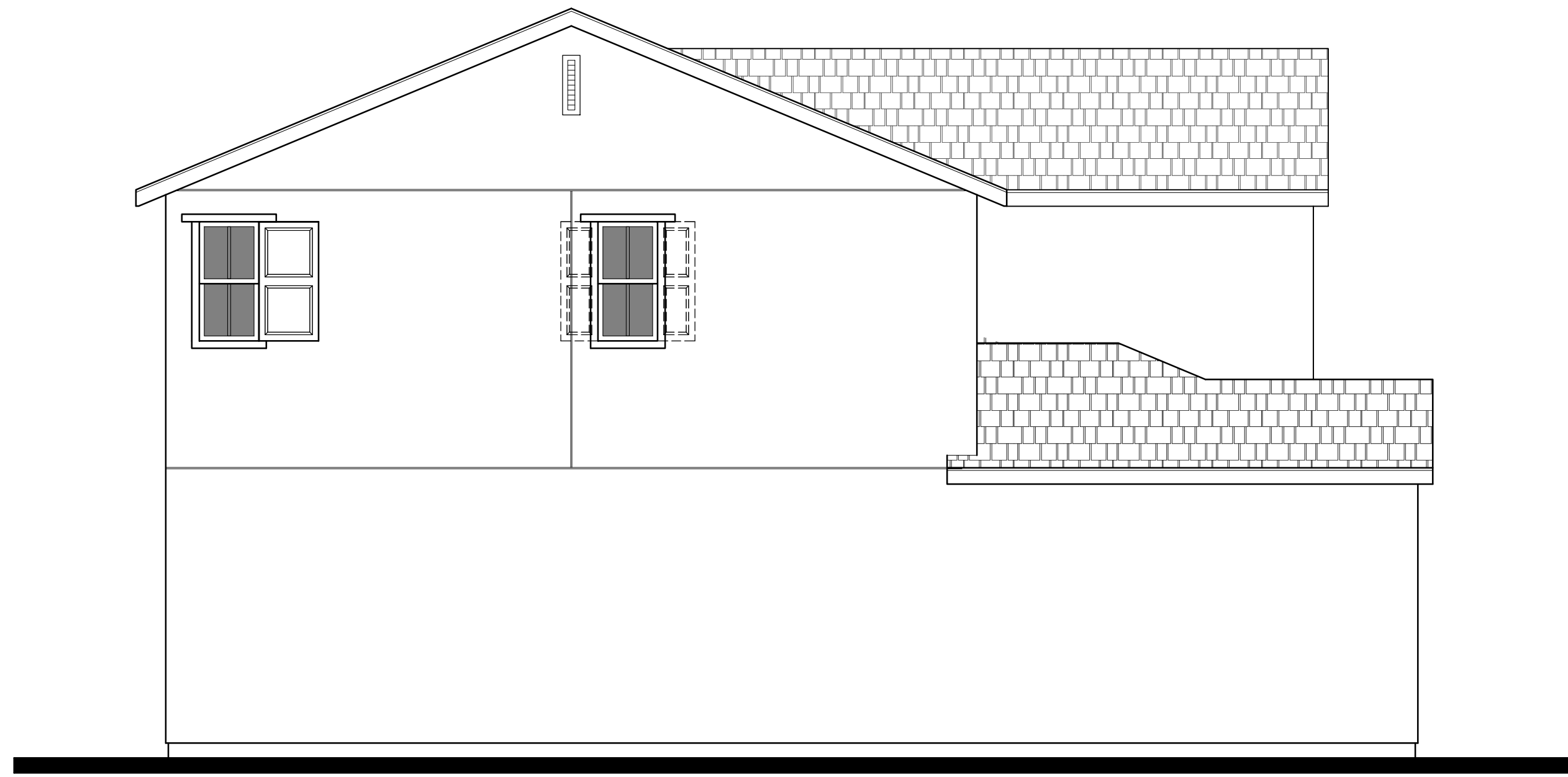

LEFT



FRONT

C - COTTAGE
1/4"=1'-0"

7'-0" HDR.
AT FRONT
8'-1"
8'-0"
9'-1"

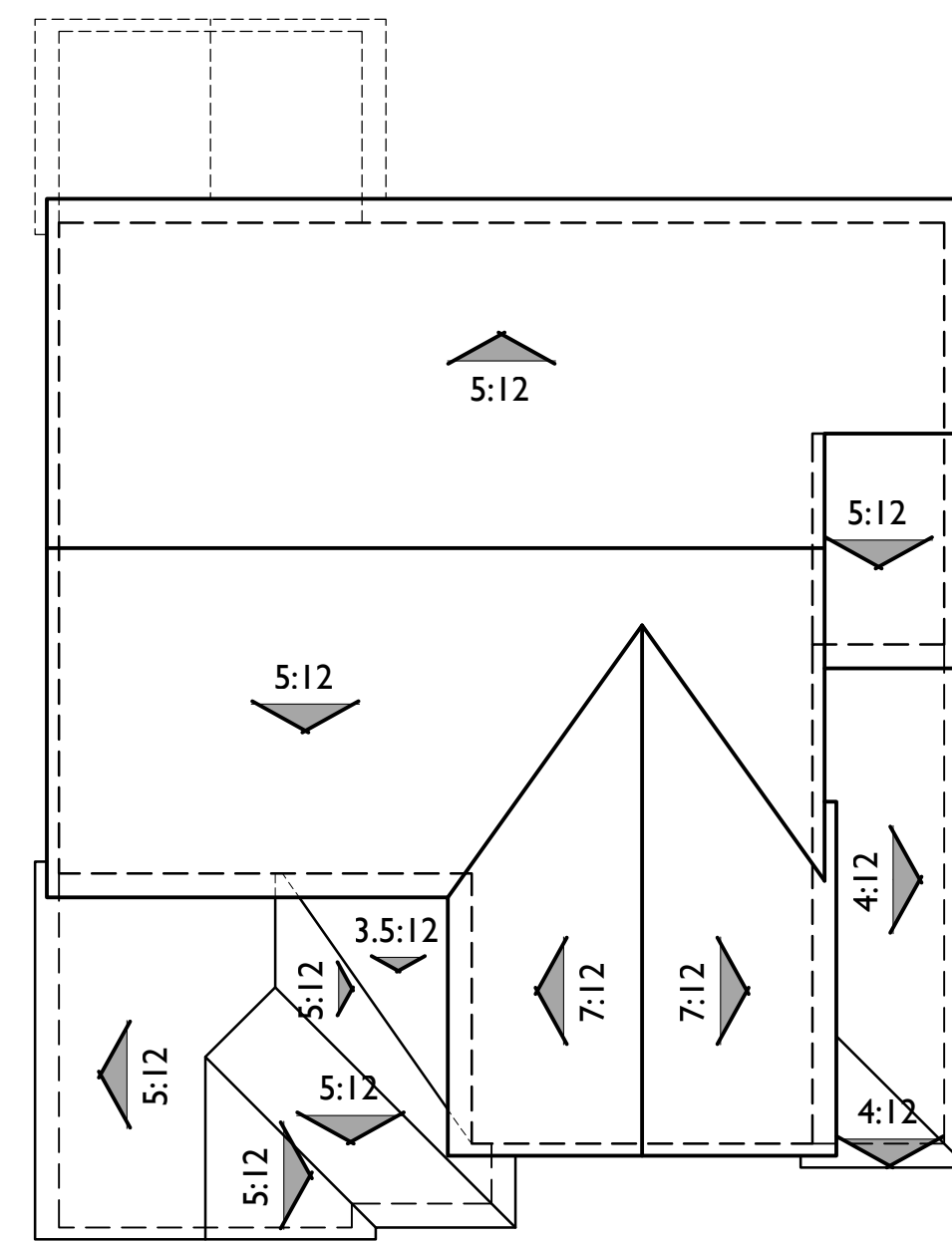

ROOF PLAN C
PITCH: 5:12 U.N.O.
RAKE: 6"
EAVE: 12"
ROOF MATERIAL: CONCRETE FLAT TILE

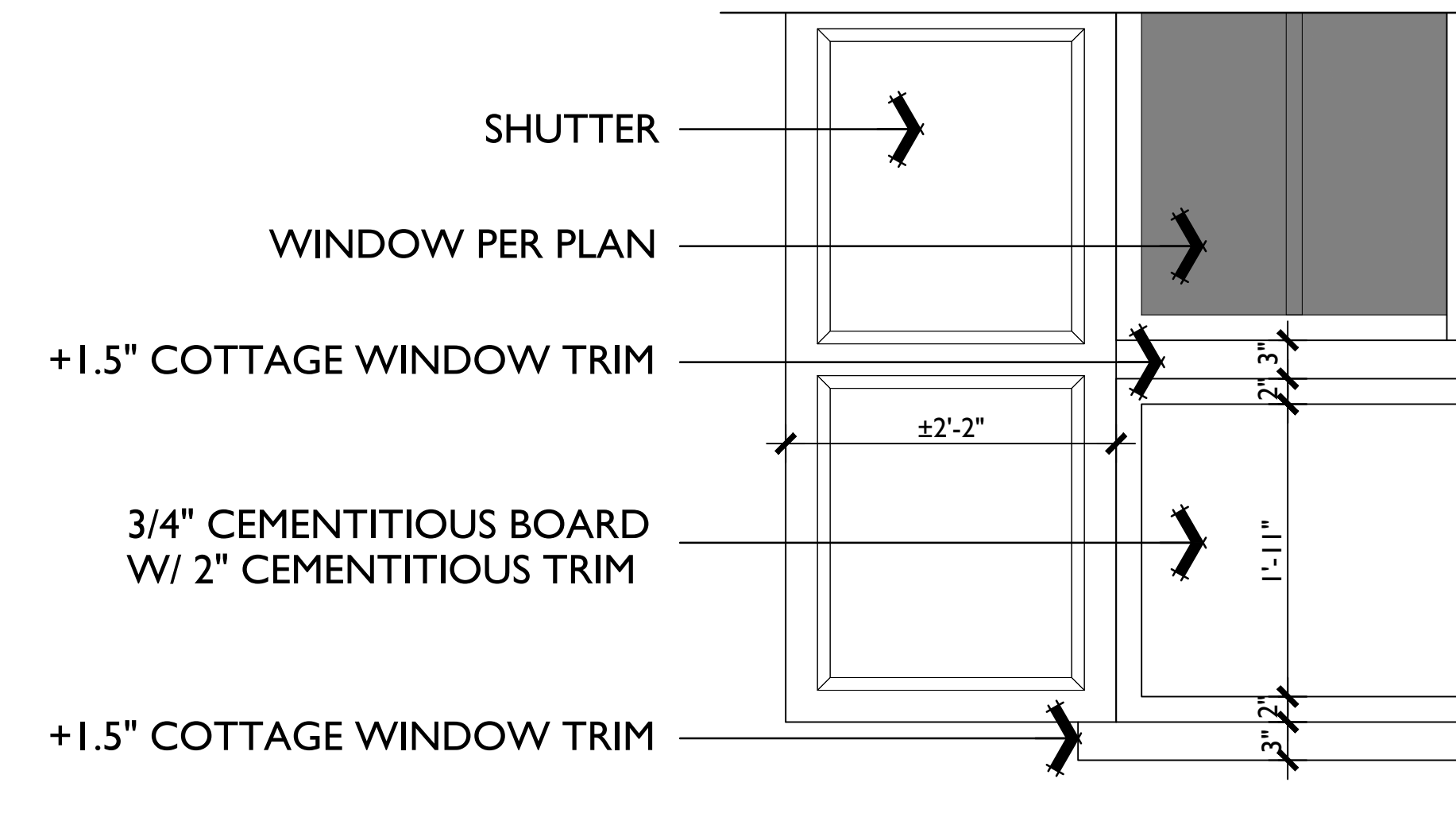

FEATURE WINDOW DETAIL
PLAN 2 COTTAGE ELEVATION



RIGHT

DASHED ENHANCEMENTS AT LOTS VISIBLE TO PUBLIC WALKWAYS, DRIVES AND PARKS. PLEASE VERIFY PER CIVIL PLOT PLAN.

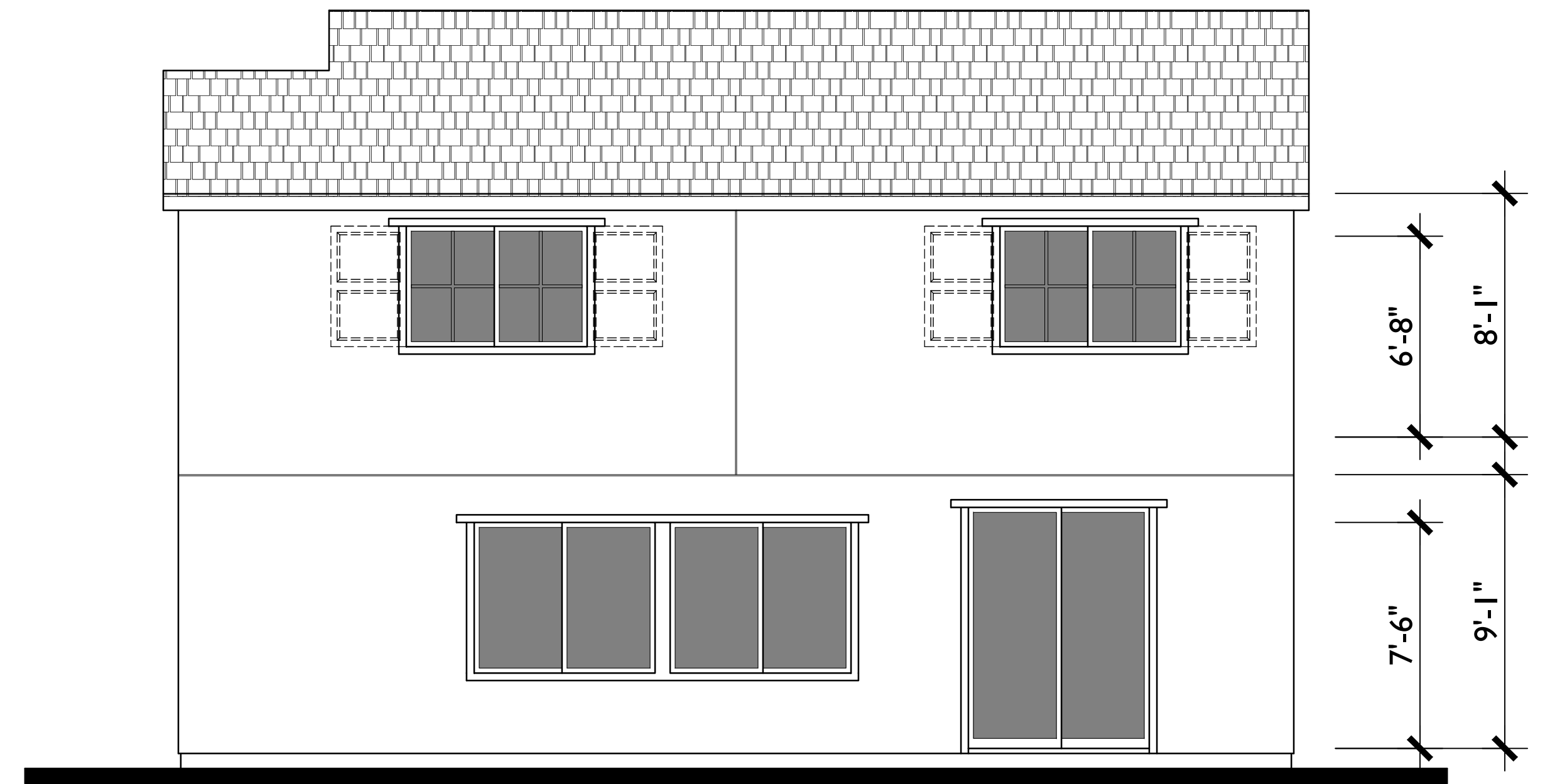

REAR

6'-8"
8'-1"
7'-6"
9'-1"

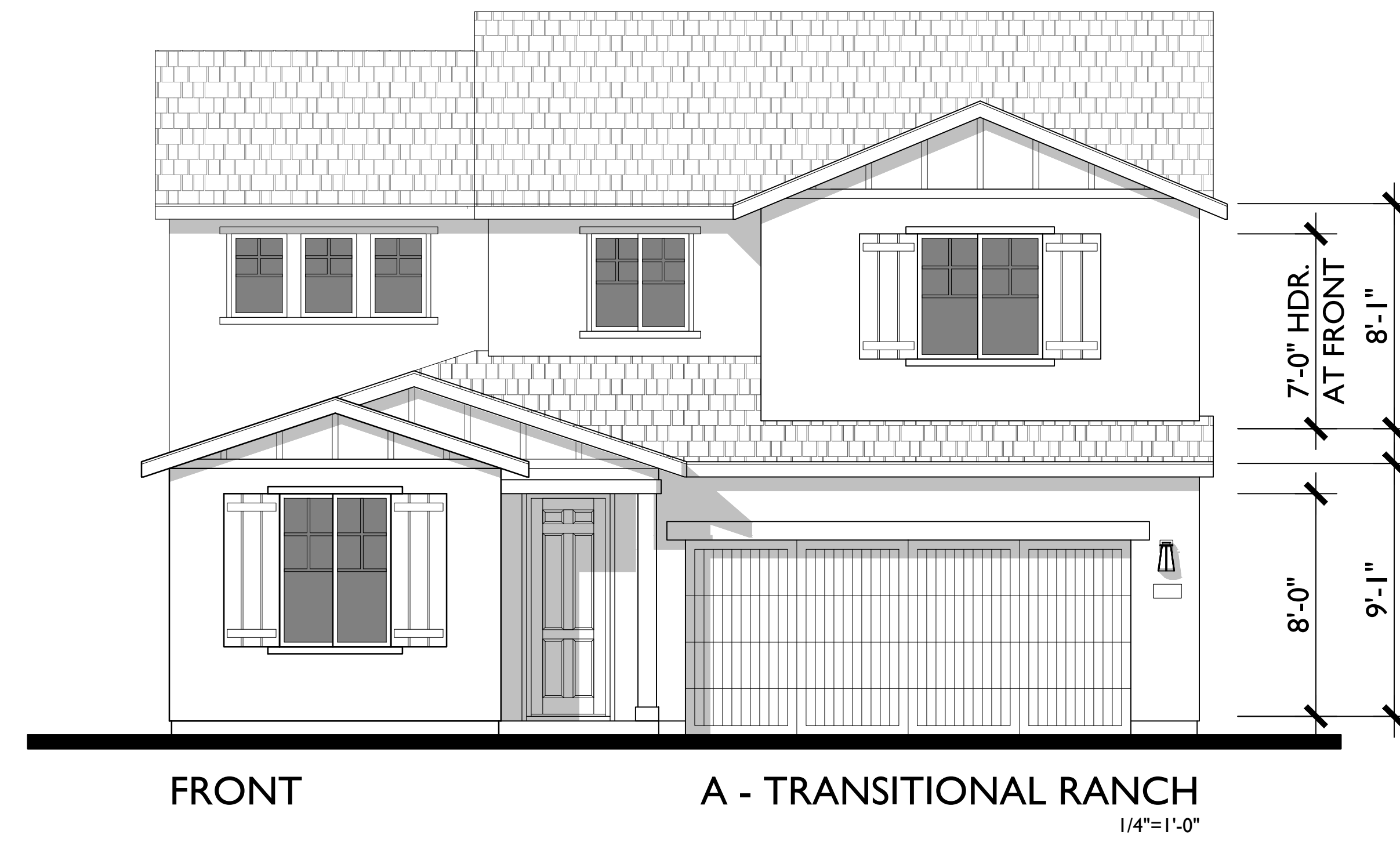

ELEVATIONS

THREE ELEVATION THEMES HAVE BEEN SELECTED FOR THIS COMMUNITY: TRANSITIONAL RANCH, FARMHOUSE AND COTTAGE. THE STYLES, ALTHOUGH DIFFERENT, ARE HARMONIOUS IN THAT THEY SHARE A COMMON AGRICULTURAL HERITAGE REINTERPRETED TO CREATE A LASTING CONTRIBUTION TO THE COMMUNITY. THIS IS ACHIEVED THROUGH APPROPRIATE USES OF EXTERIOR MATERIAL, ARTICULATION OF ENTRY DETAILS (ARCHES, POSTS, AND PORCHES) ALONG WITH VARYING ROOF PITCHES SPECIFIC TO EACH STYLE.

TRANSITIONAL RANCH

THE TRANSITIONAL RANCH USES A LOW ROOF PITCH AND HAS GABLE END ACCENTS, SHUTTERS, AND POTSELVES AT SELECT LOCATIONS.

FARMHOUSE

THE FARMHOUSE IS A CLASSIC STYLE USING STEEP ROOF PITCHES ALONG WITH BOARD AND BATTEN ACCENTS AND APPROPRIATELY THEMED LIGHTING.

COTTAGE

THE COTTAGE ALSO HAS STEEP ACCENT ROOFS AND HANDSOME SHUTTERS TO ACCENT THE WINDOWS AND IN THE CASE OF PLANS 1 AND 3 HAVE A GRACEFUL SOFT ARCH TO HIGHLIGHT THE ENTRY.

THEME SPECIFIC COACH LIGHTS, FRONT DOORS AND GARAGE DOORS ADD THE FINISHING TOUCHES TO THIS PLAN SERIES.

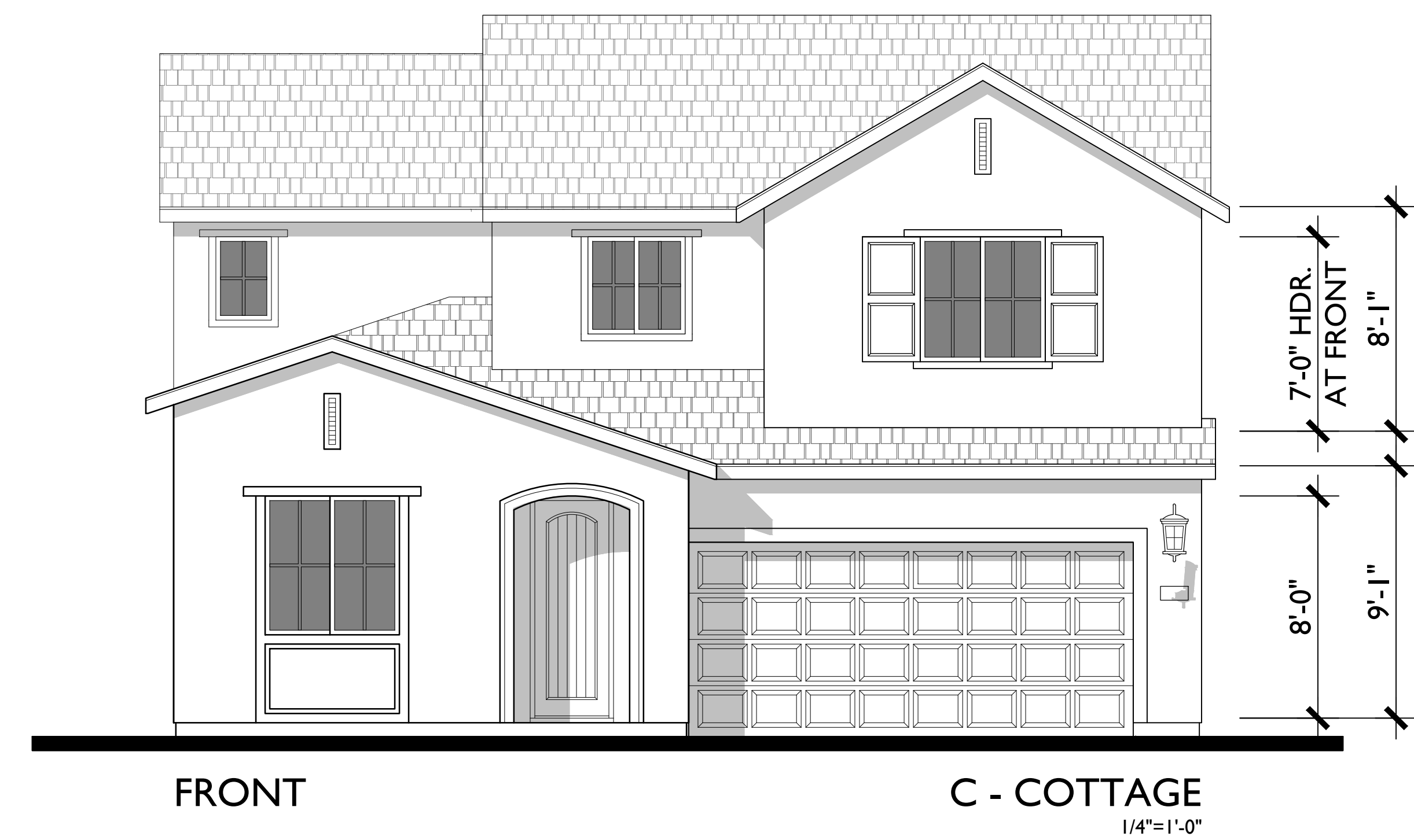
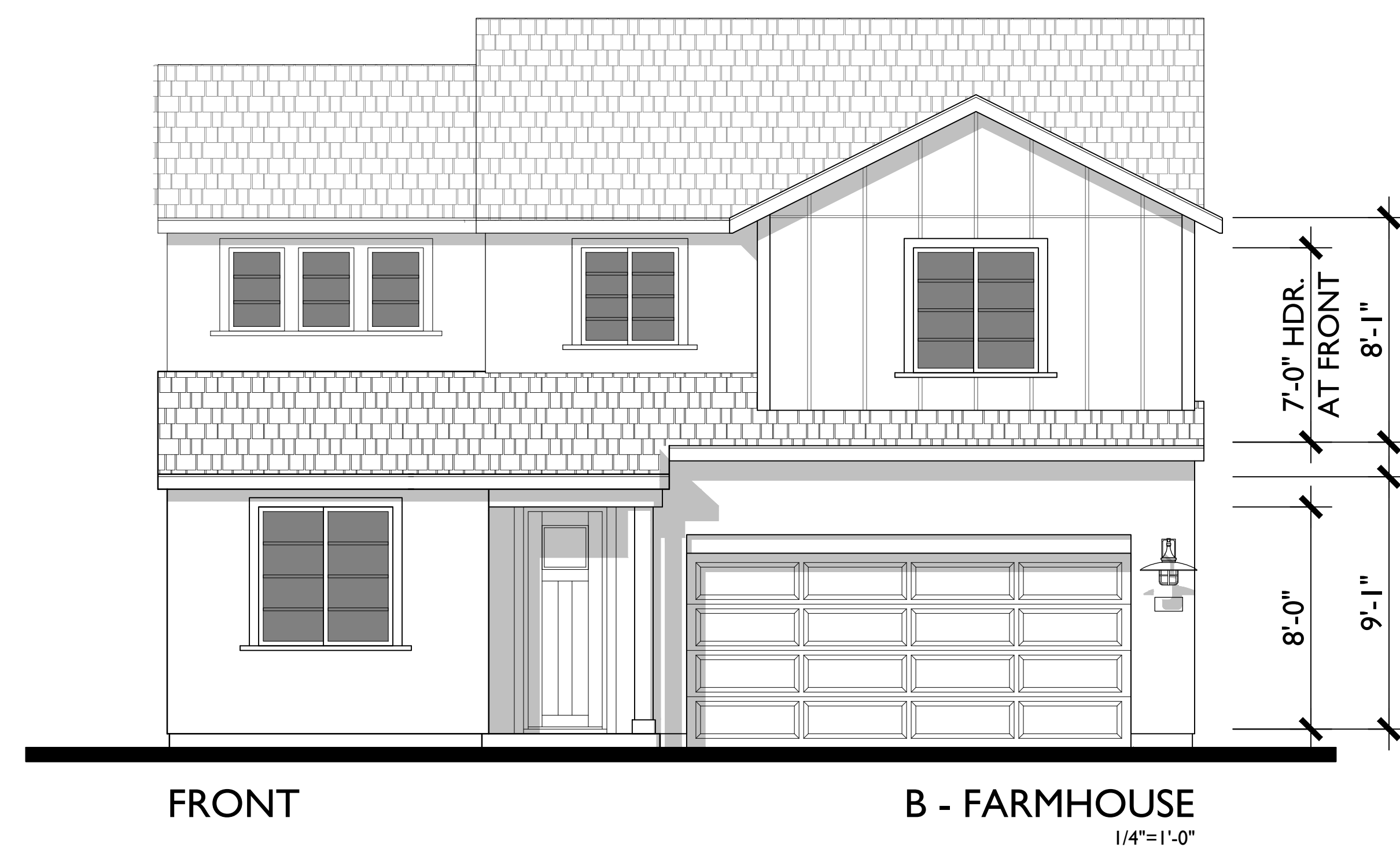

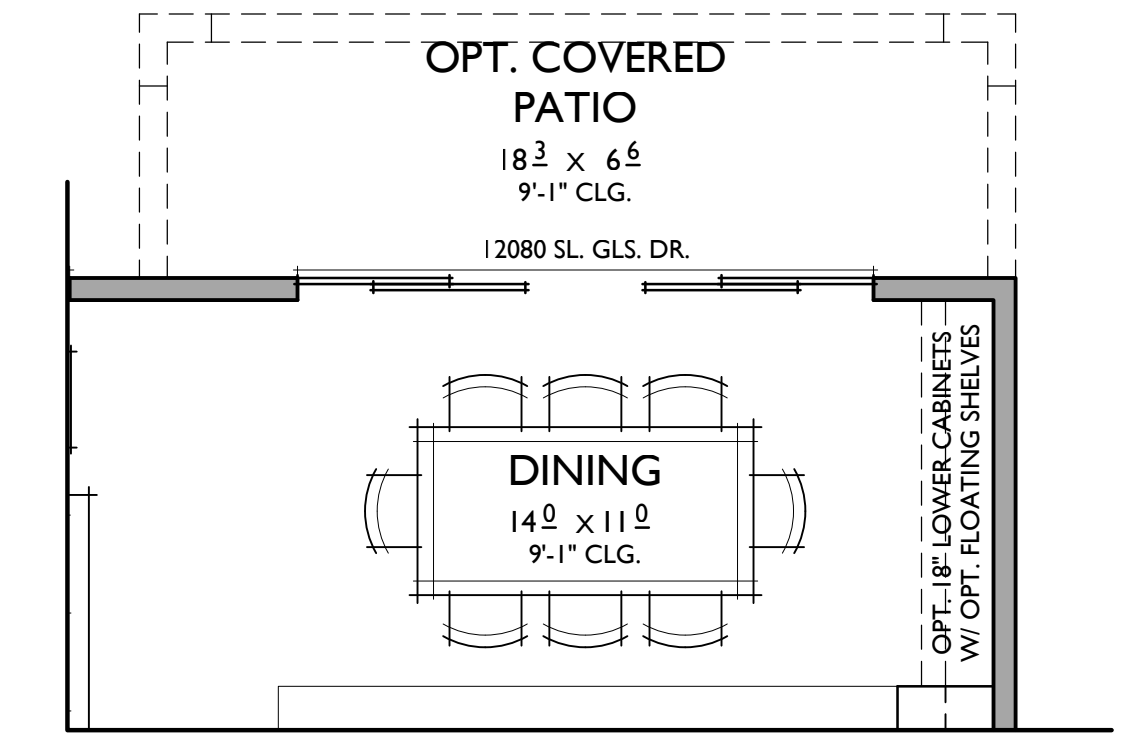
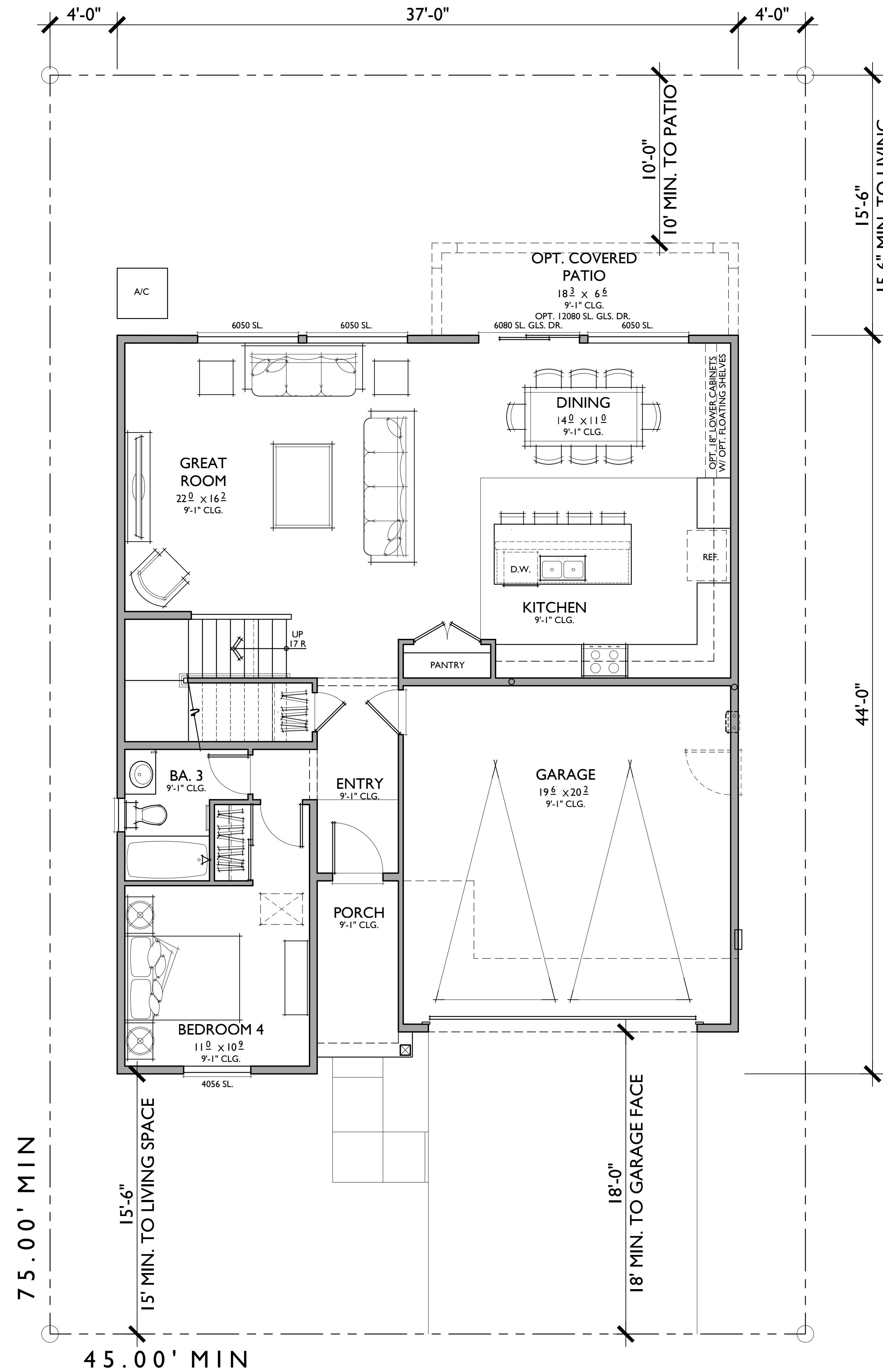
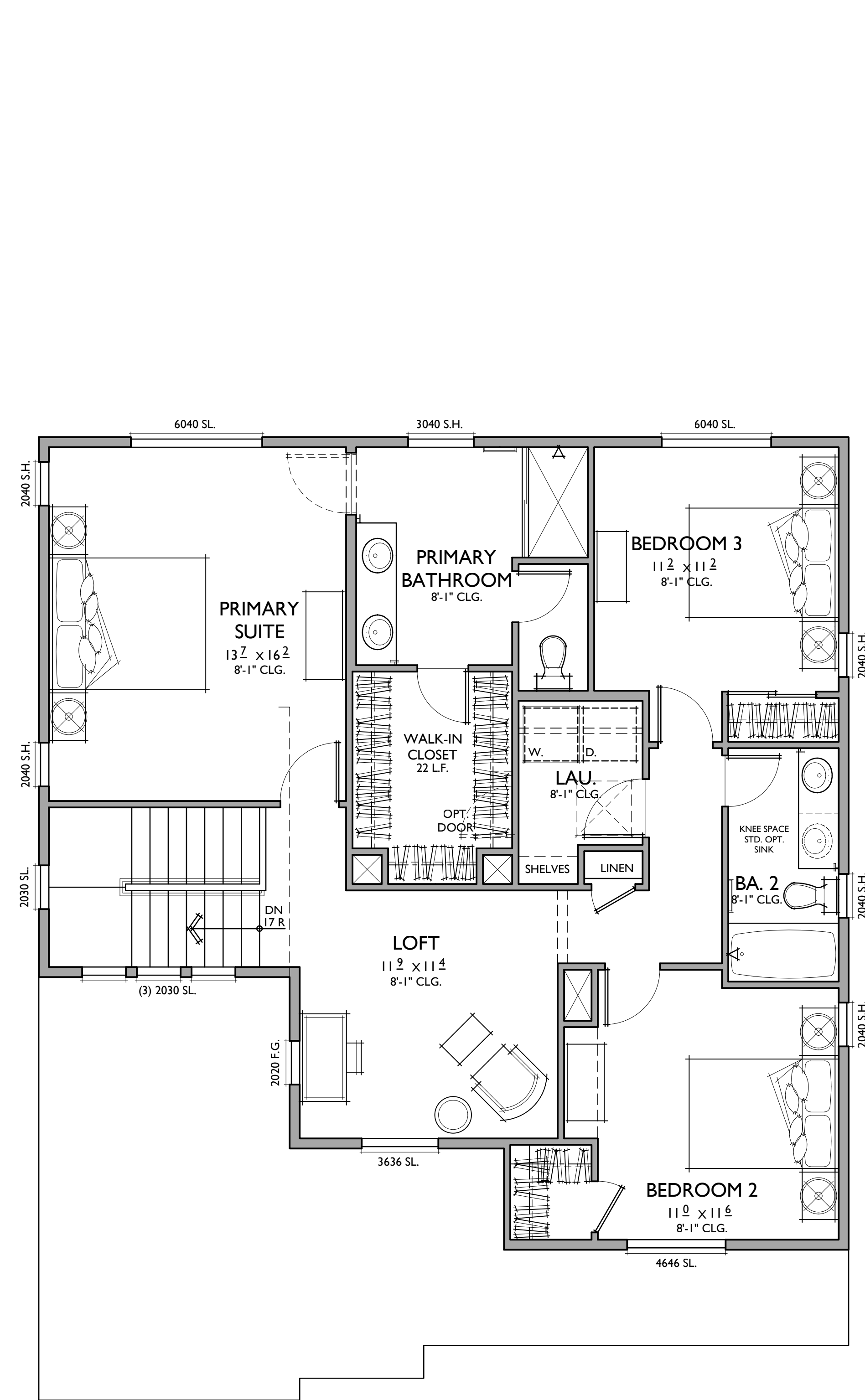

OPTIONAL 12080 GLIDER AT DINING

PLAN 3A
2,215 SQ. FT.

TARGET: 2,210 SQ. FT.
4 BEDROOMS / 3 BATHS + LOFT
2 - CAR GARAGE

FLOOR AREA TABLE

1ST FLOOR	1108 SQ. FT.
2ND FLOOR	1107 SQ. FT.
TOTAL LIVING	2,215 SQ. FT.
2 - CAR GARAGE	414 SQ. FT.
PORCH	52 SQ. FT.
OPT. COVERED PATIO	101 SQ. FT.

NOTE: SQUARE FOOTAGE MAY VARY DUE TO METHOD OF CALCULATION

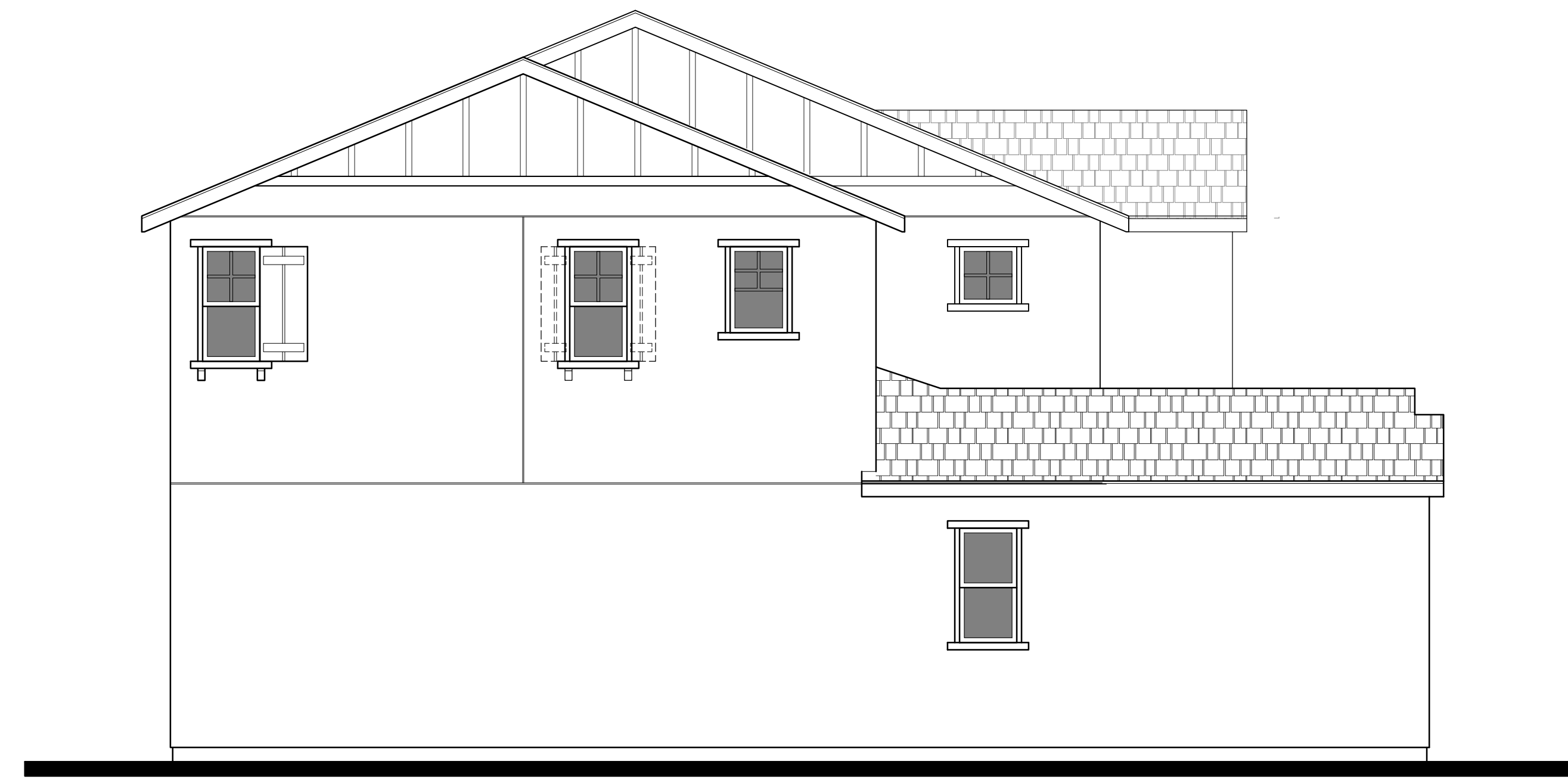

LEFT



FRONT

A - TRANSITIONAL RANCH

1/4"=1'-0"

7'-0" HDR.
AT FRONT
8'-1"
8'-0"
9'-1"

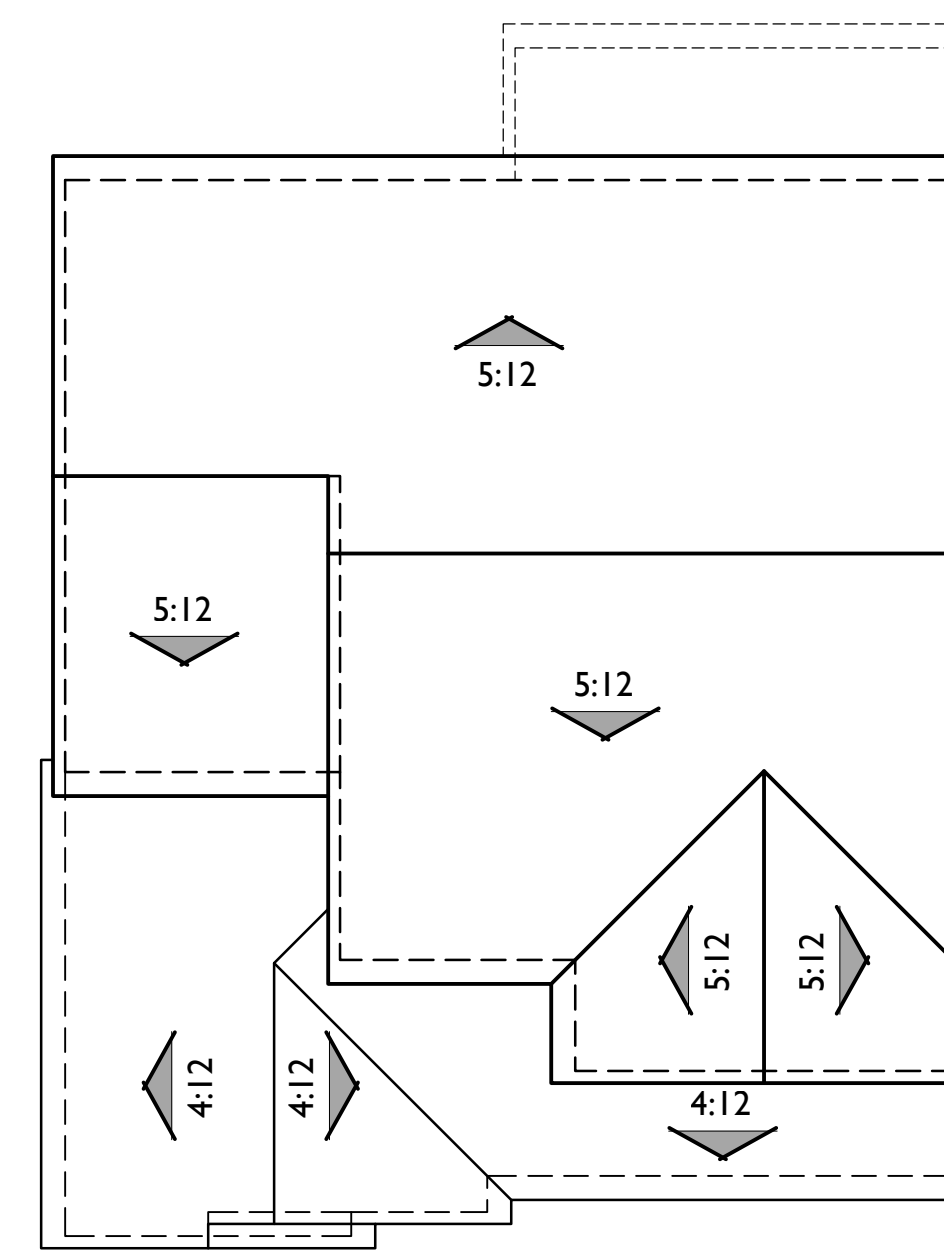

ROOF PLAN A
 PITCH: 5:12 U.N.O.
 RAKE: 6"
 EAVE: 12"
 ROOF MATERIAL: COMPOSITION SHINGLE



RIGHT

DASHED ENHANCEMENTS AT LOTS VISIBLE TO PUBLIC WALKWAYS, DRIVES AND PARKS. PLEASE VERIFY PER CIVIL PLOT PLAN.

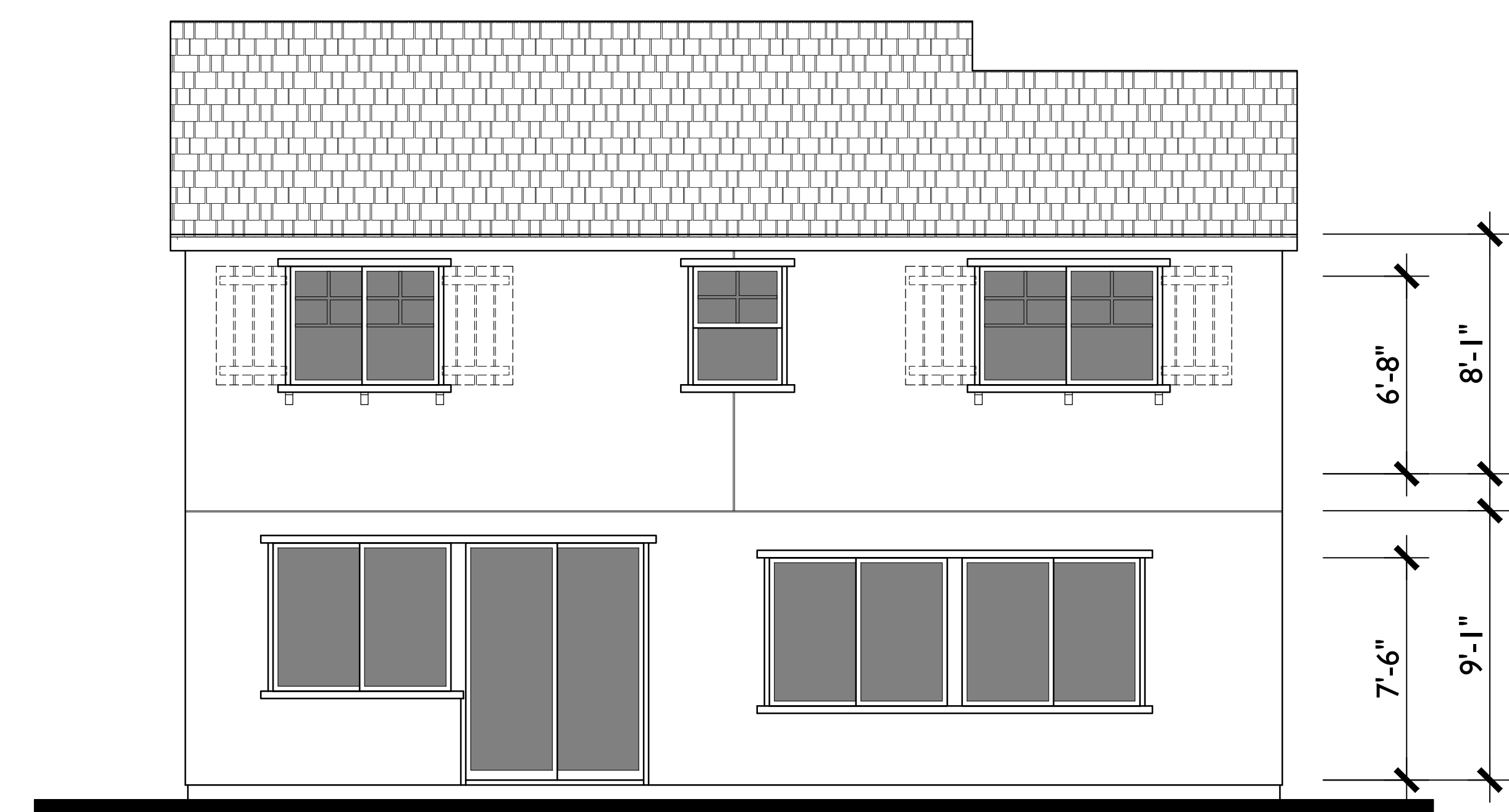

REAR

6'-8"
8'-1"
7'-6"
9'-1"

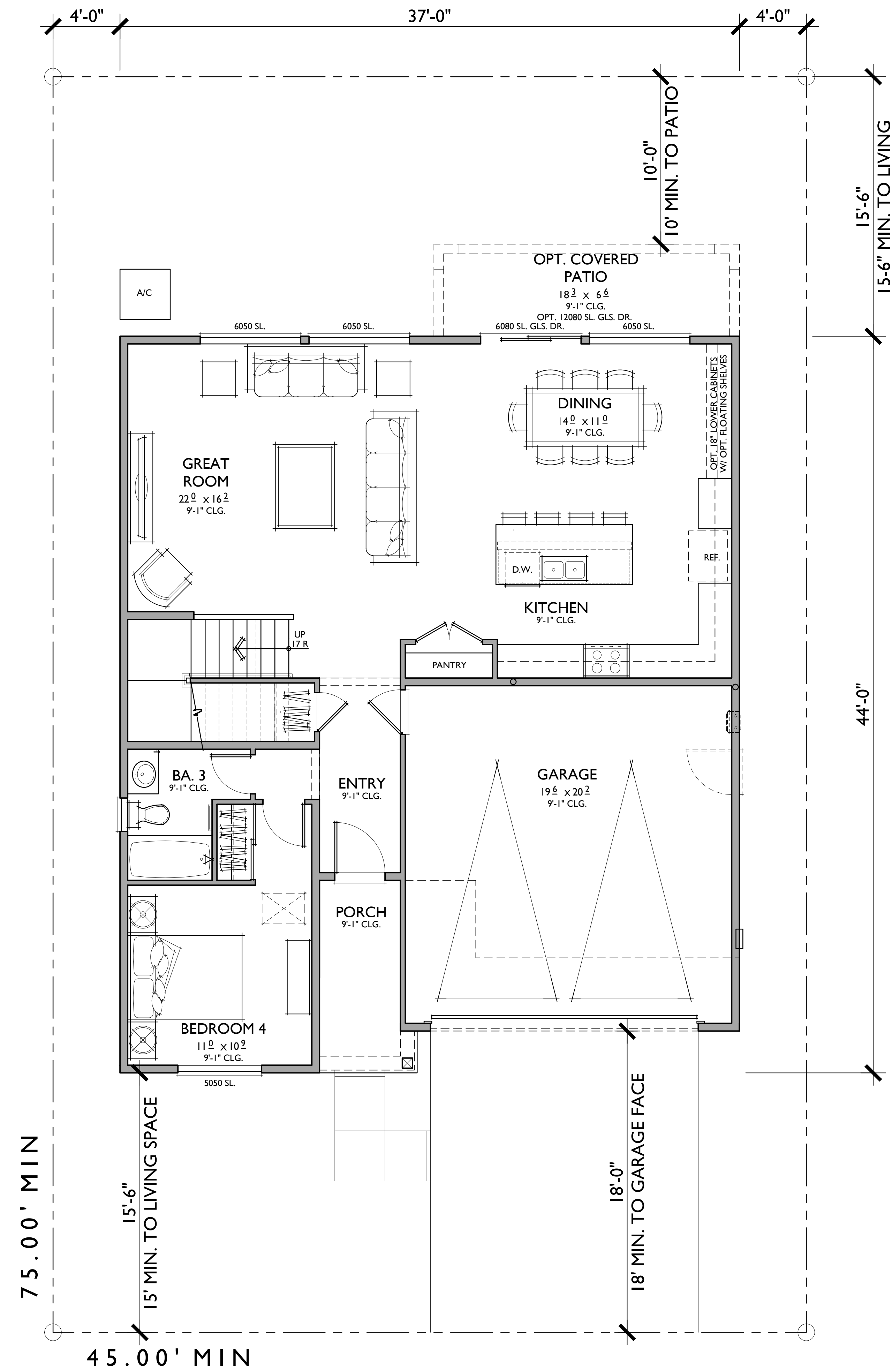
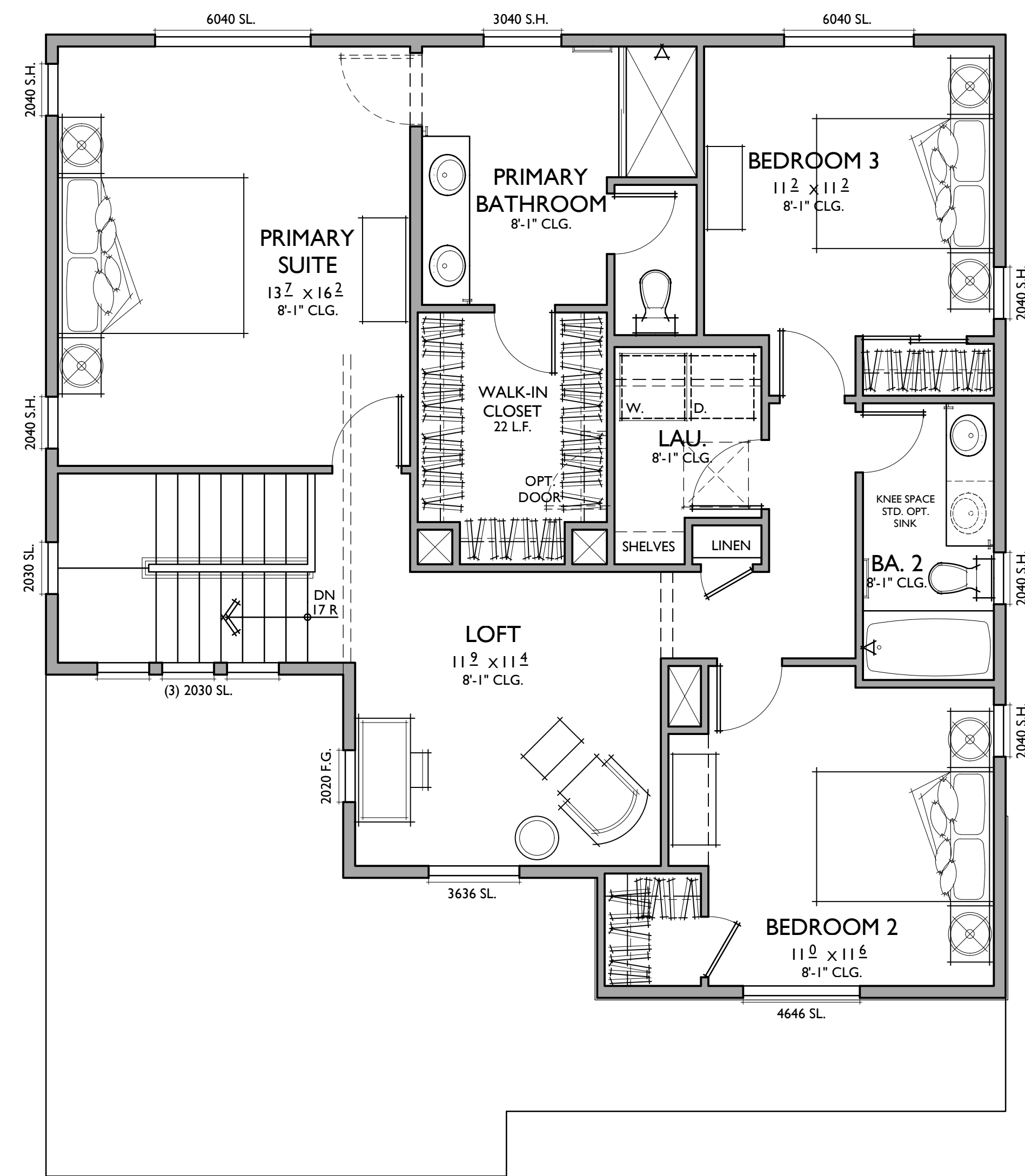

PLAN 3B
2,215 SQ. FT.

TARGET: 2,210 SQ. FT.
4 BEDROOMS / 3 BATHS + LOFT
2 - CAR GARAGE

FLOOR AREA TABLE	
1ST FLOOR	1108 SQ. FT.
2ND FLOOR	1107 SQ. FT.
TOTAL LIVING	2,215 SQ. FT.
2 - CAR GARAGE	414 SQ. FT.
PORCH	57 SQ. FT.
OPT. COVERED PATIO	101 SQ. FT.

NOTE: SQUARE FOOTAGE MAY VARY DUE TO METHOD OF CALCULATION

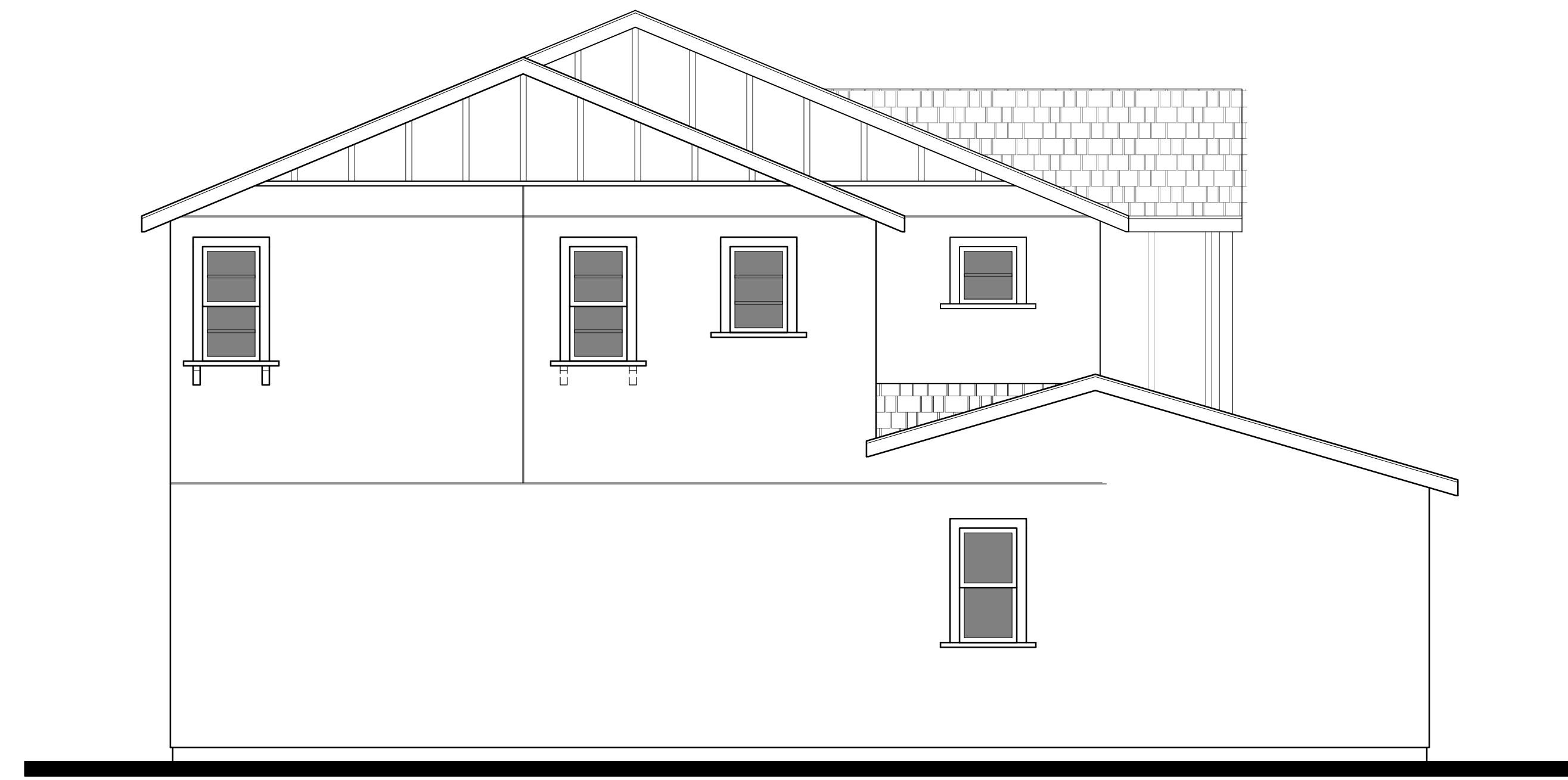

LEFT



FRONT

B - FARMHOUSE
1/4"=1'-0"

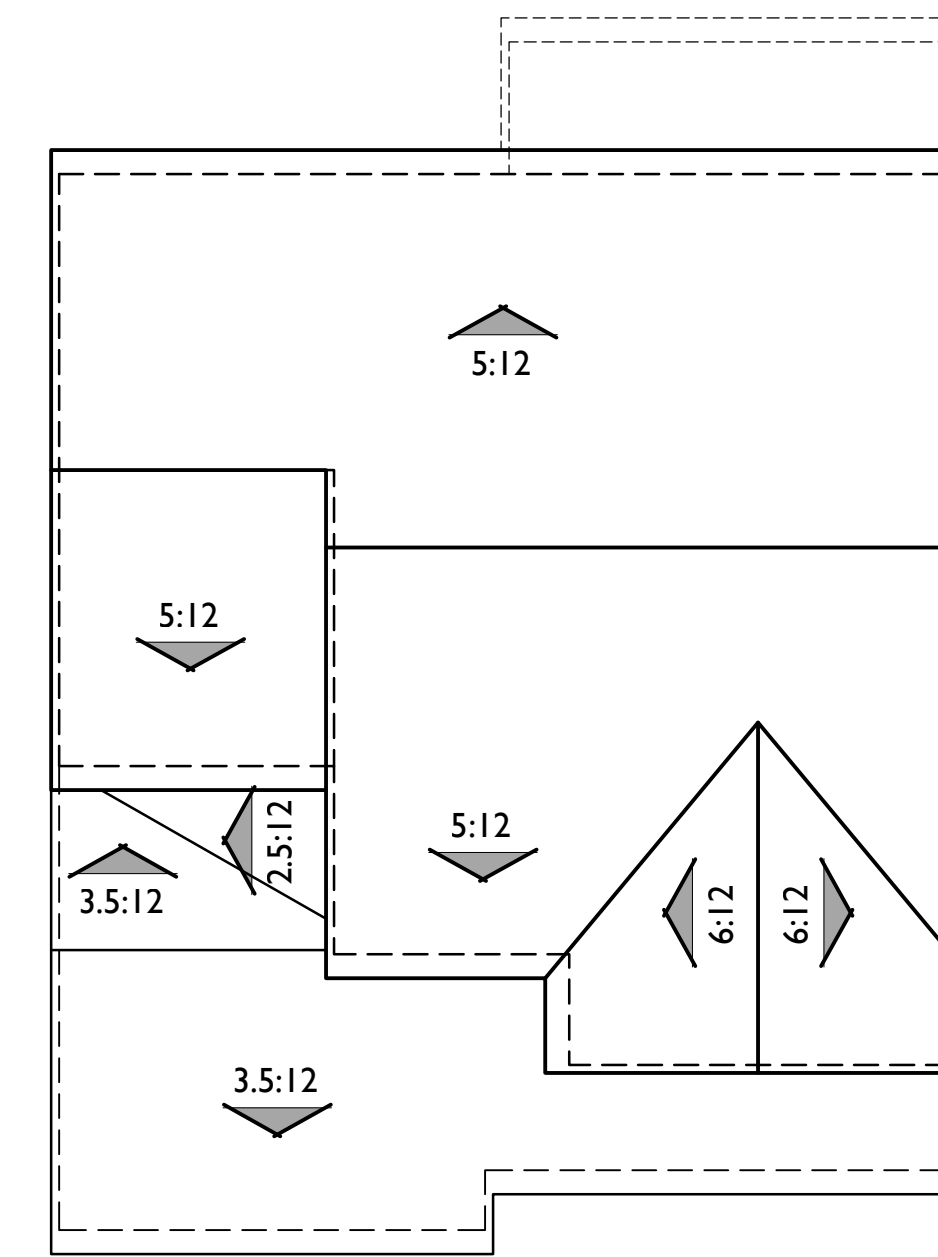

ROOF PLAN B
PITCH: 5:12 U.N.O.
RAKE: 4"
EAVE: 12"
ROOF MATERIAL: COMPOSITION SHINGLE



RIGHT

DASHED ENHANCEMENTS AT LOTS VISIBLE TO PUBLIC WALKWAYS, DRIVES AND PARKS. PLEASE VERIFY PER CIVIL PLOT PLAN.

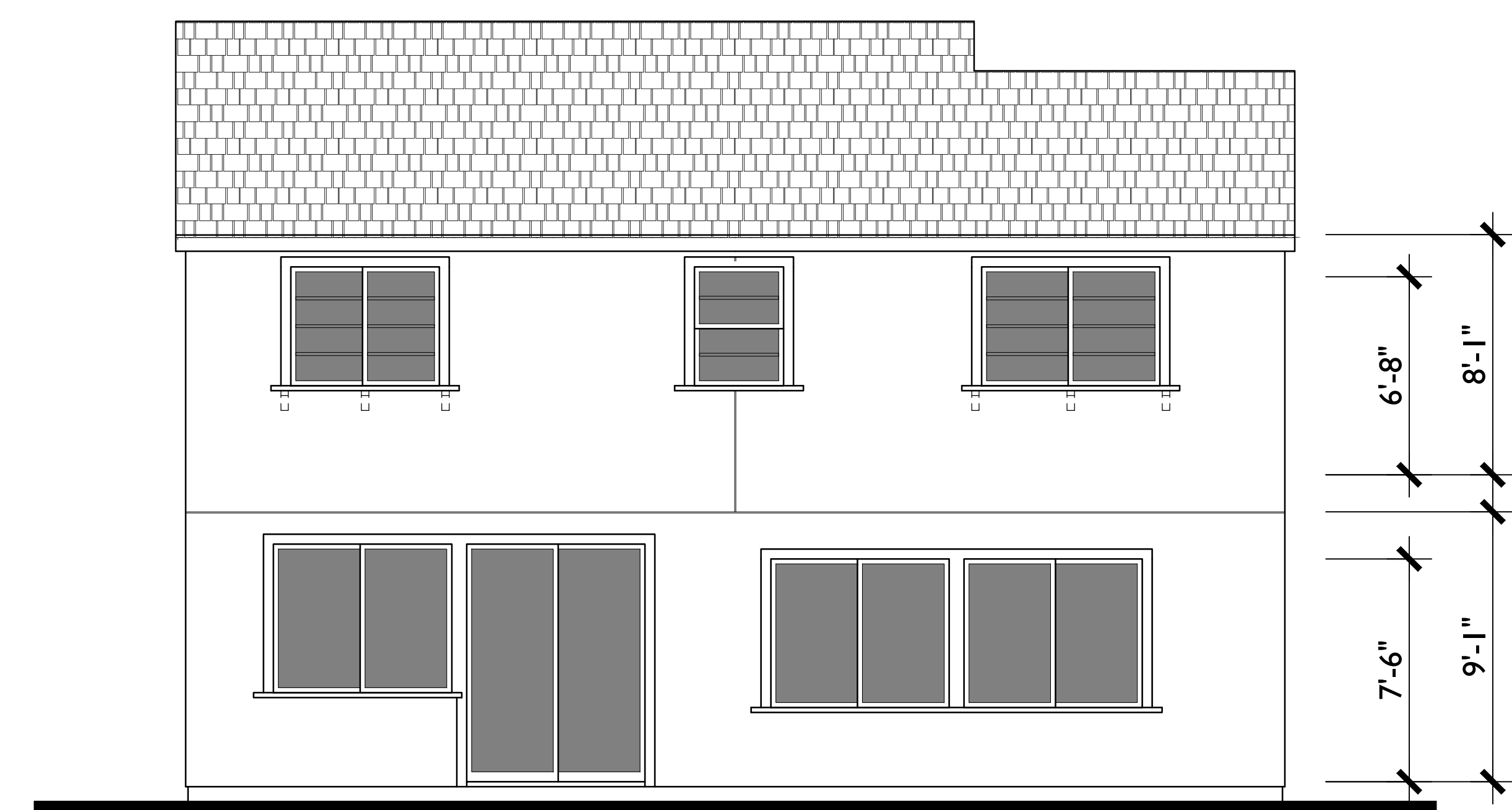

REAR

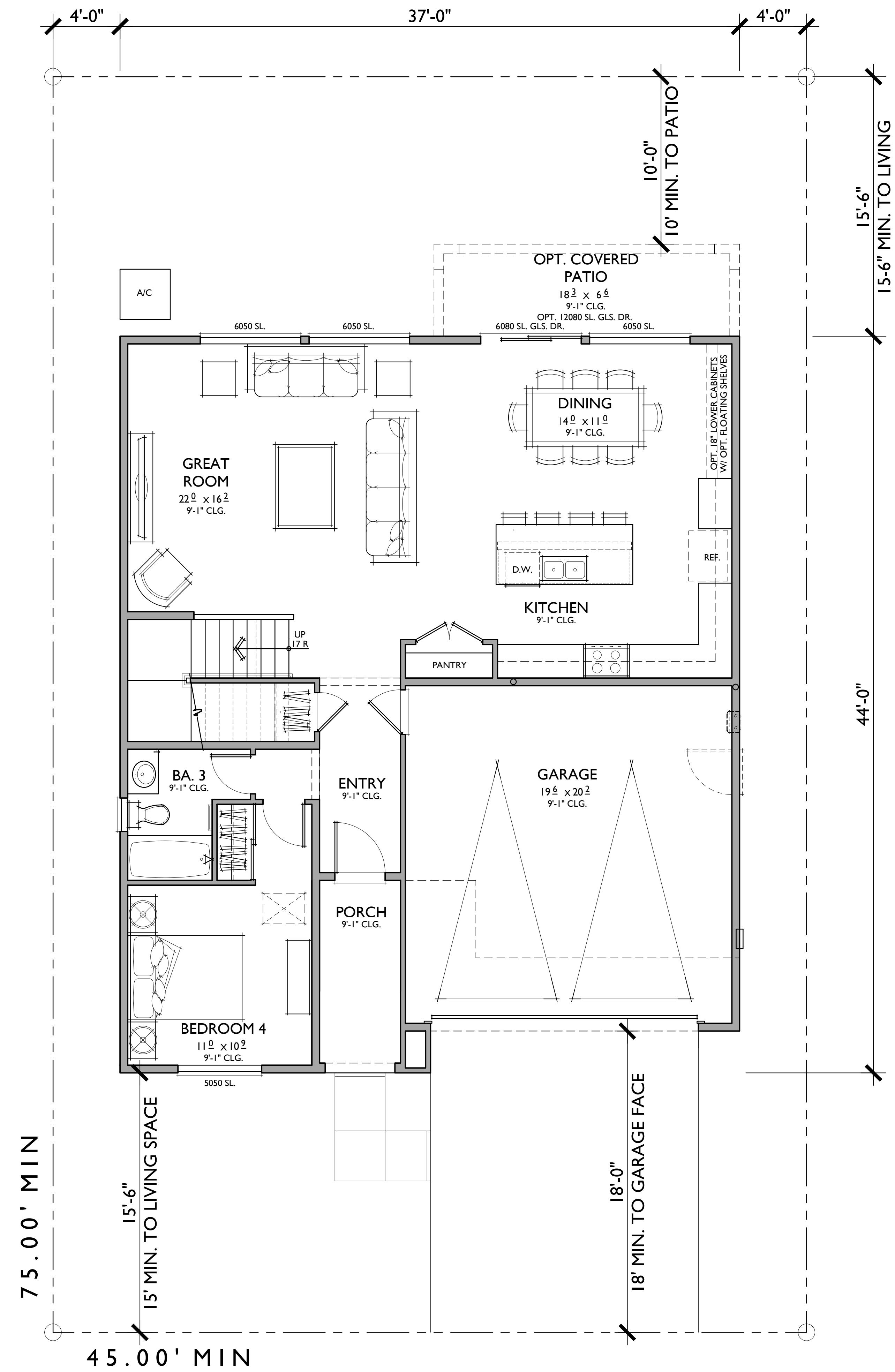
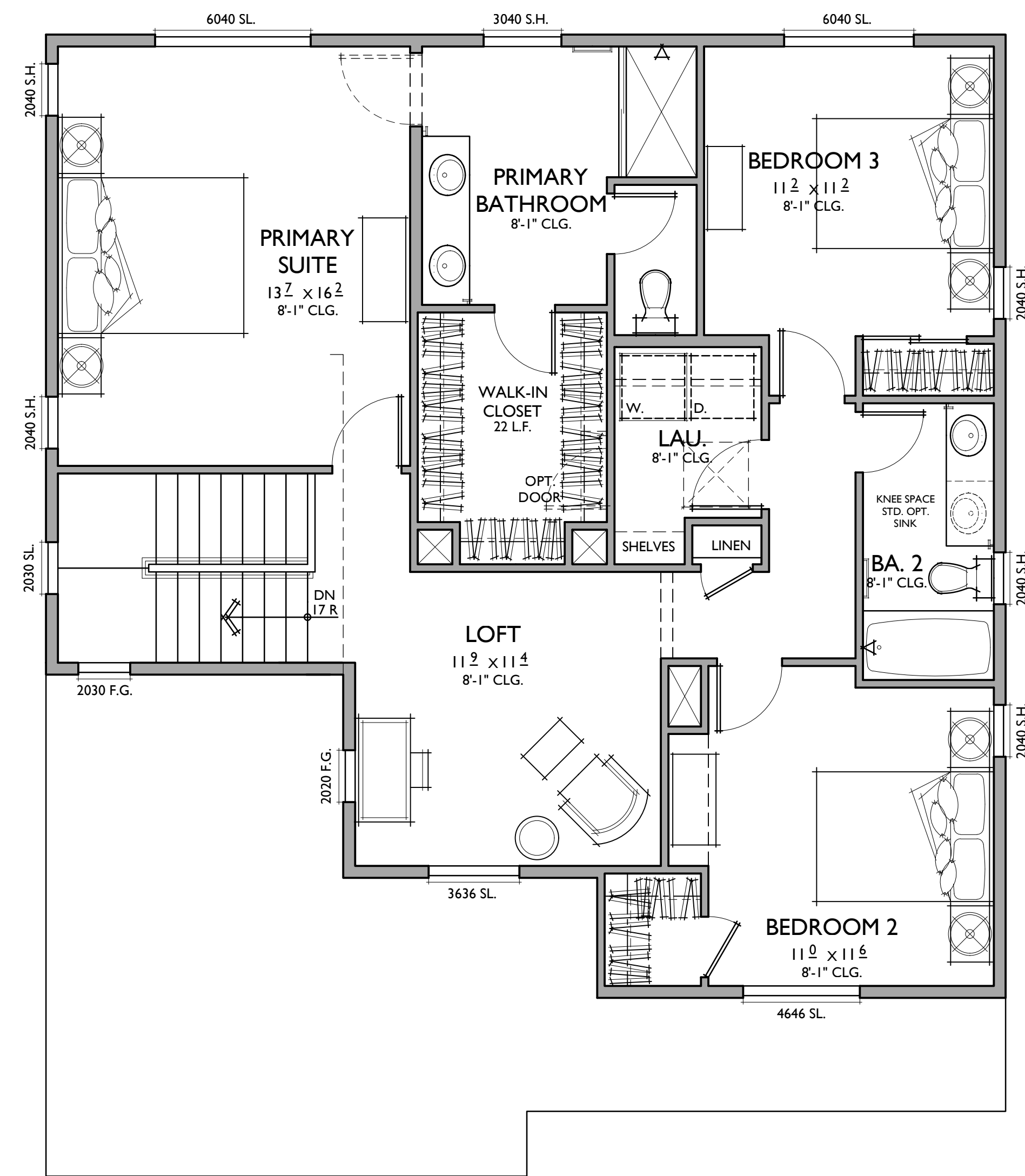

PLAN 3C

2,215 SQ. FT.

TARGET: 2,210 SQ. FT.
 4 BEDROOMS / 3 BATHS + LOFT
 2 - CAR GARAGE

FLOOR AREA TABLE	
1ST FLOOR	1108 SQ. FT.
2ND FLOOR	1107 SQ. FT.
TOTAL LIVING	2,215 SQ. FT.
2 - CAR GARAGE	414 SQ. FT.
PORCH	60 SQ. FT.
OPT. COVERED PATIO	101 SQ. FT.

NOTE: SQUARE FOOTAGE MAY VARY DUE TO METHOD OF CALCULATION

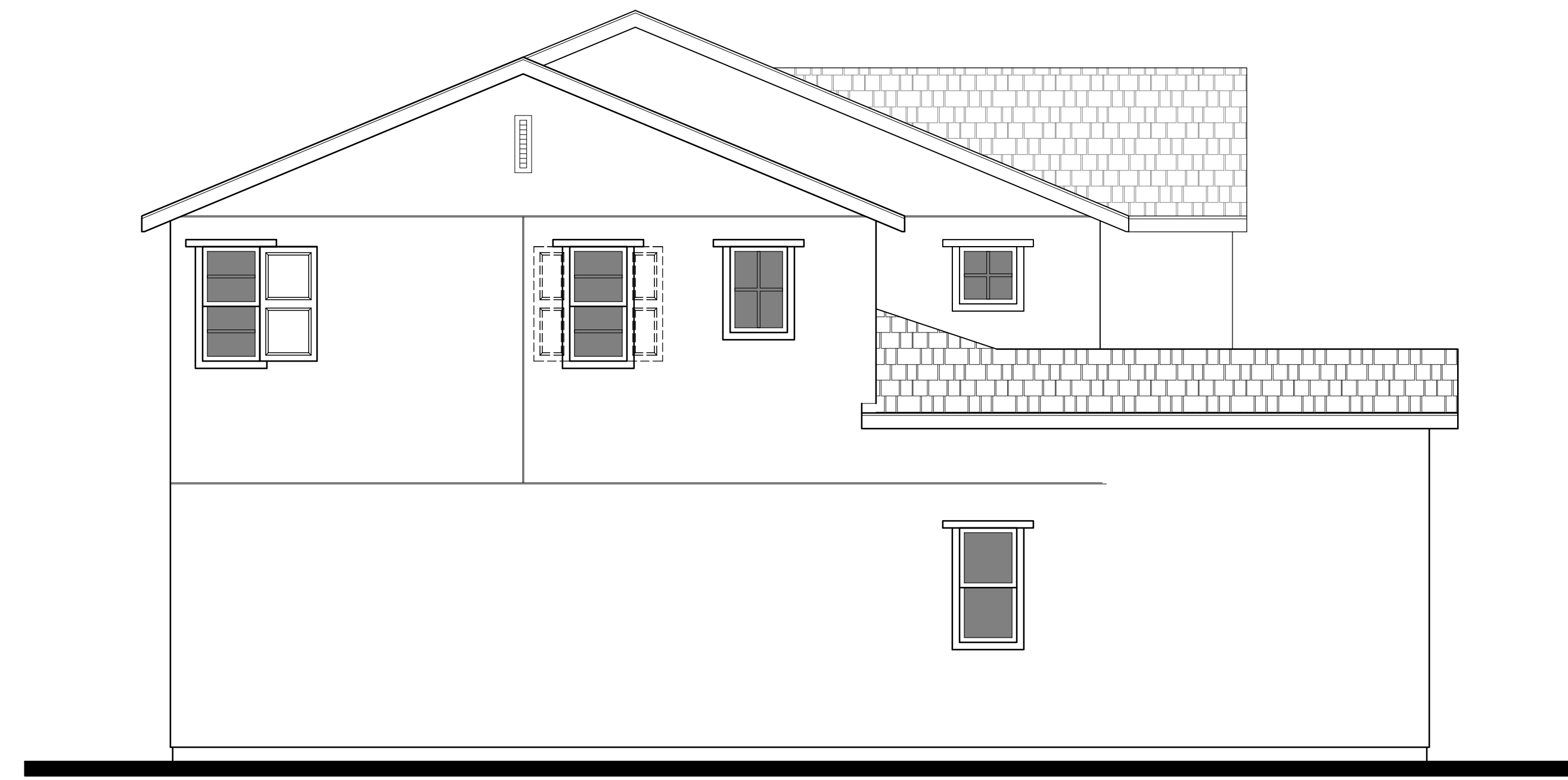

LEFT



FRONT

C - COTTAGE
1/4"=1'-0"

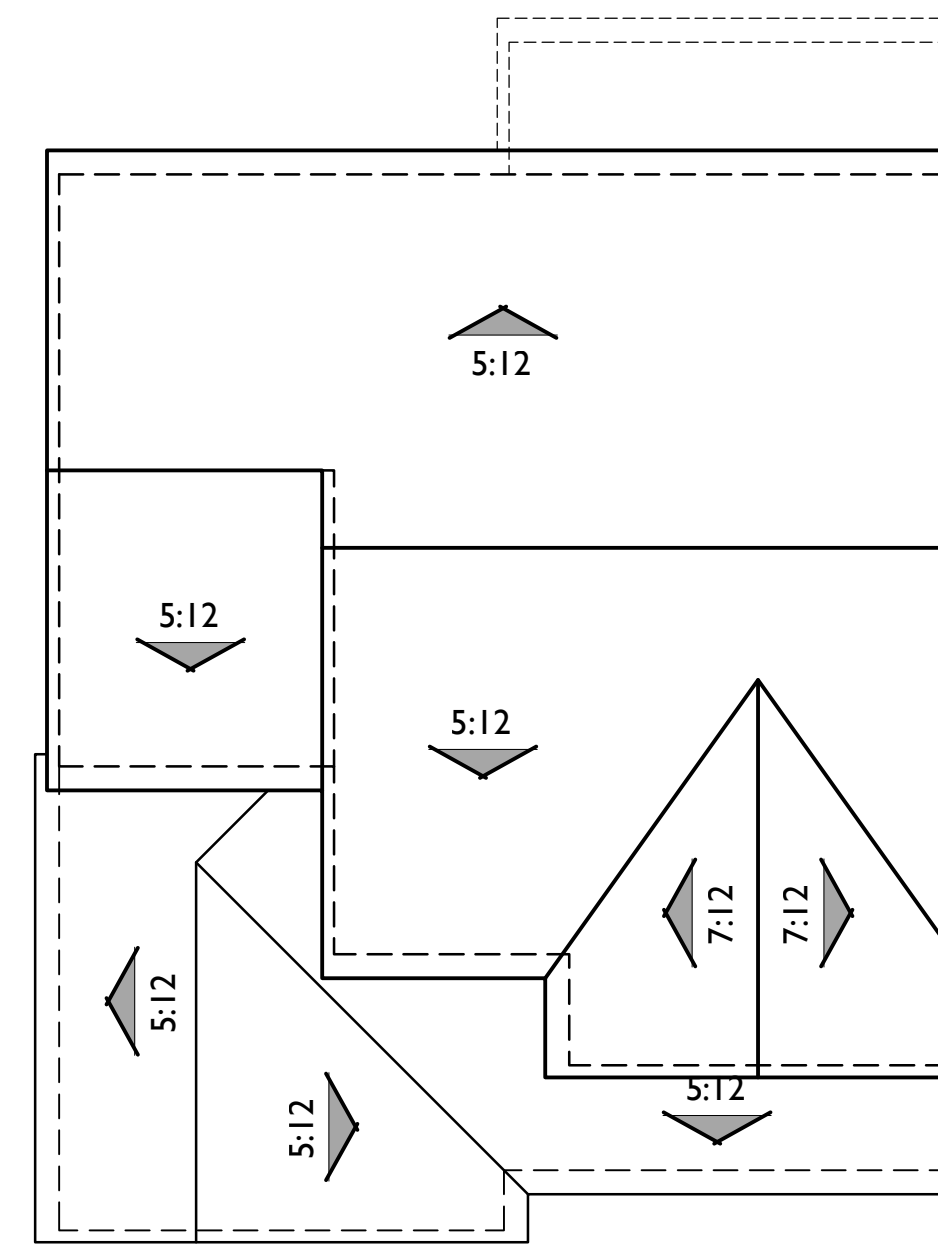

ROOF PLAN C
PITCH: 5:12 U.N.O.
RAKE: 6"
EAVE: 12"
ROOF MATERIAL: COMPOSITION SHINGLE

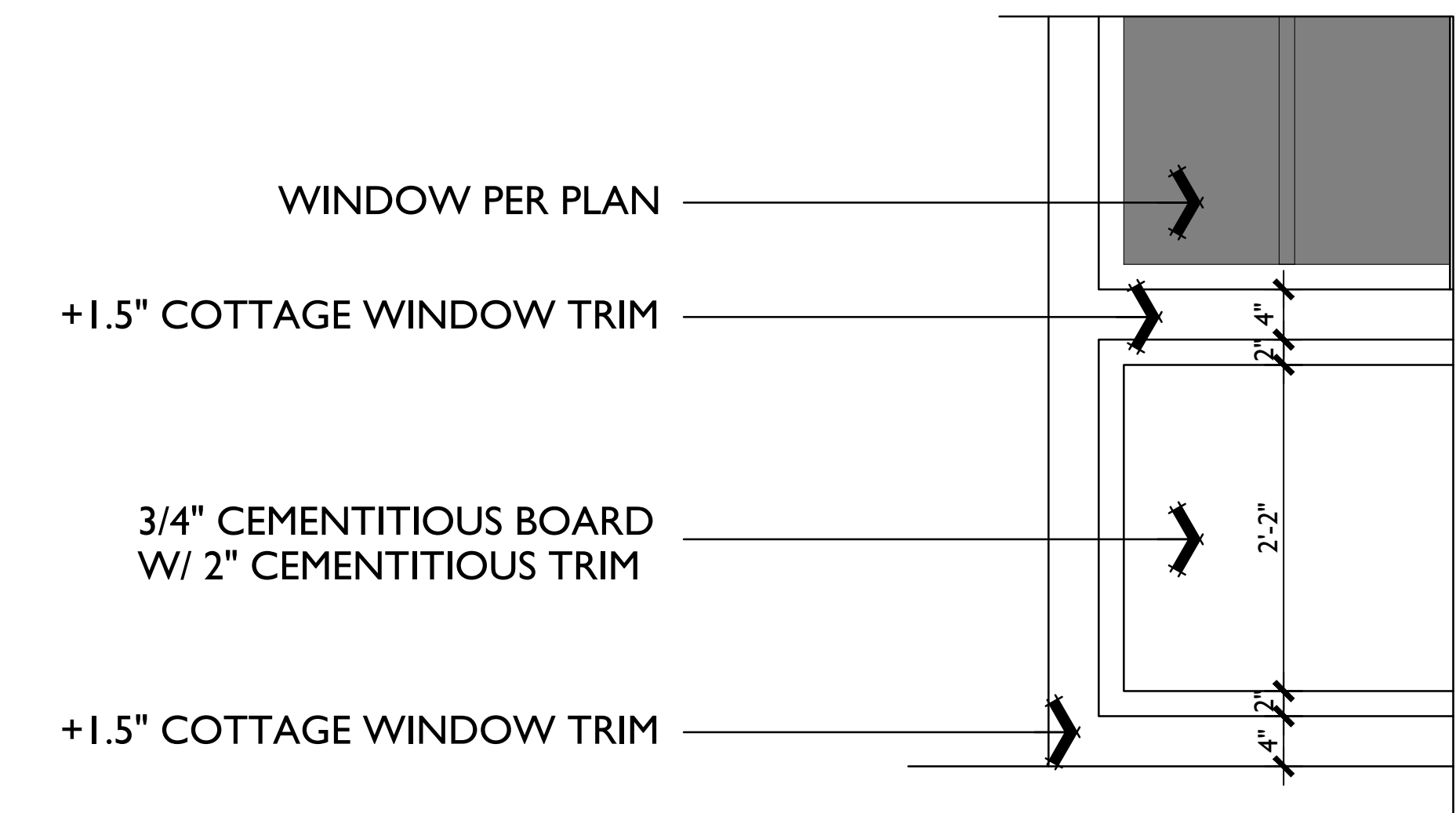

FEATURE WINDOW DETAIL
PLAN 3 COTTAGE ELEVATION

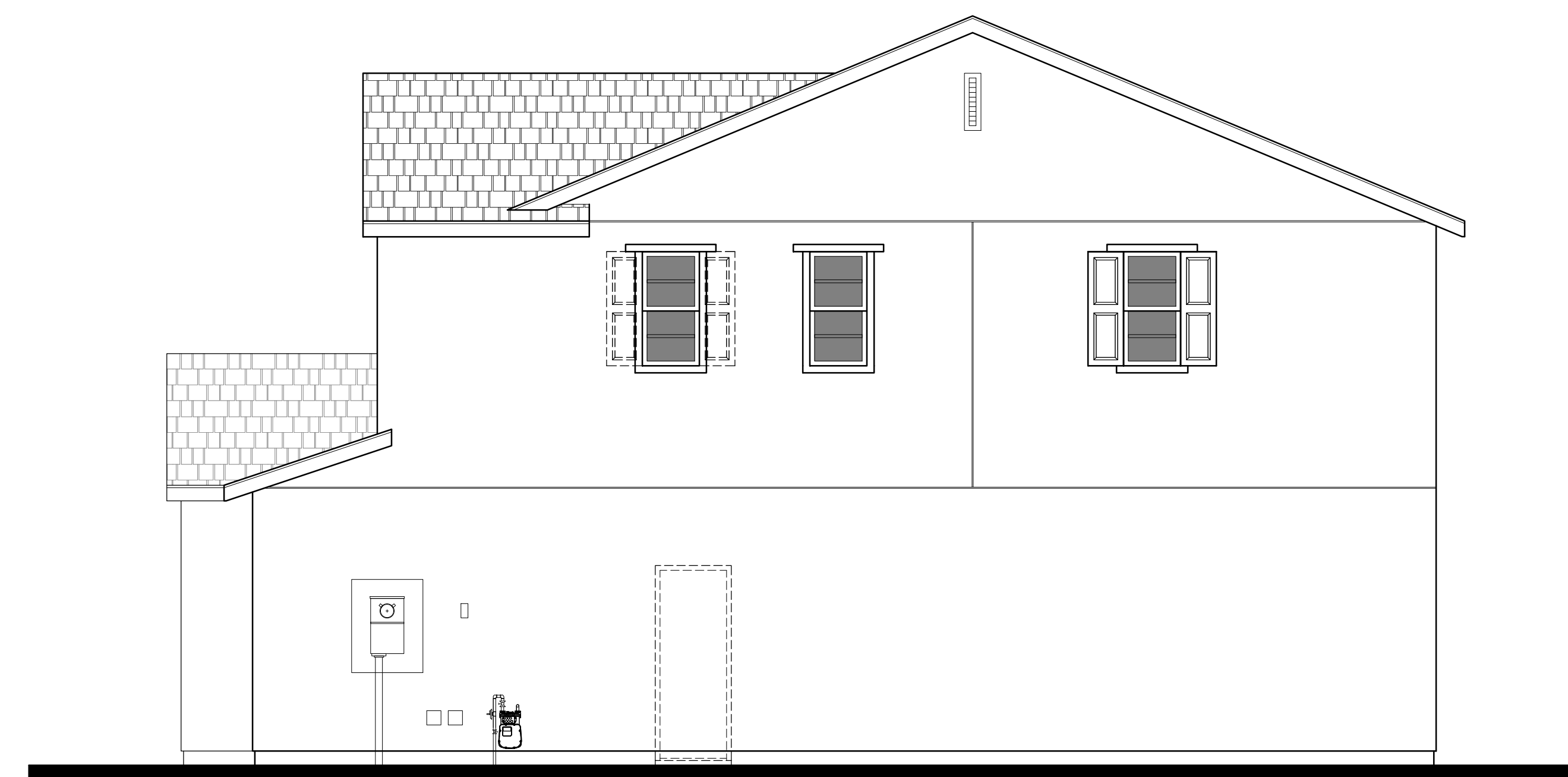

RIGHT

DASHED ENHANCEMENTS AT LOTS VISIBLE TO PUBLIC WALKWAYS, DRIVES AND PARKS. PLEASE VERIFY PER CIVIL PLOT PLAN.

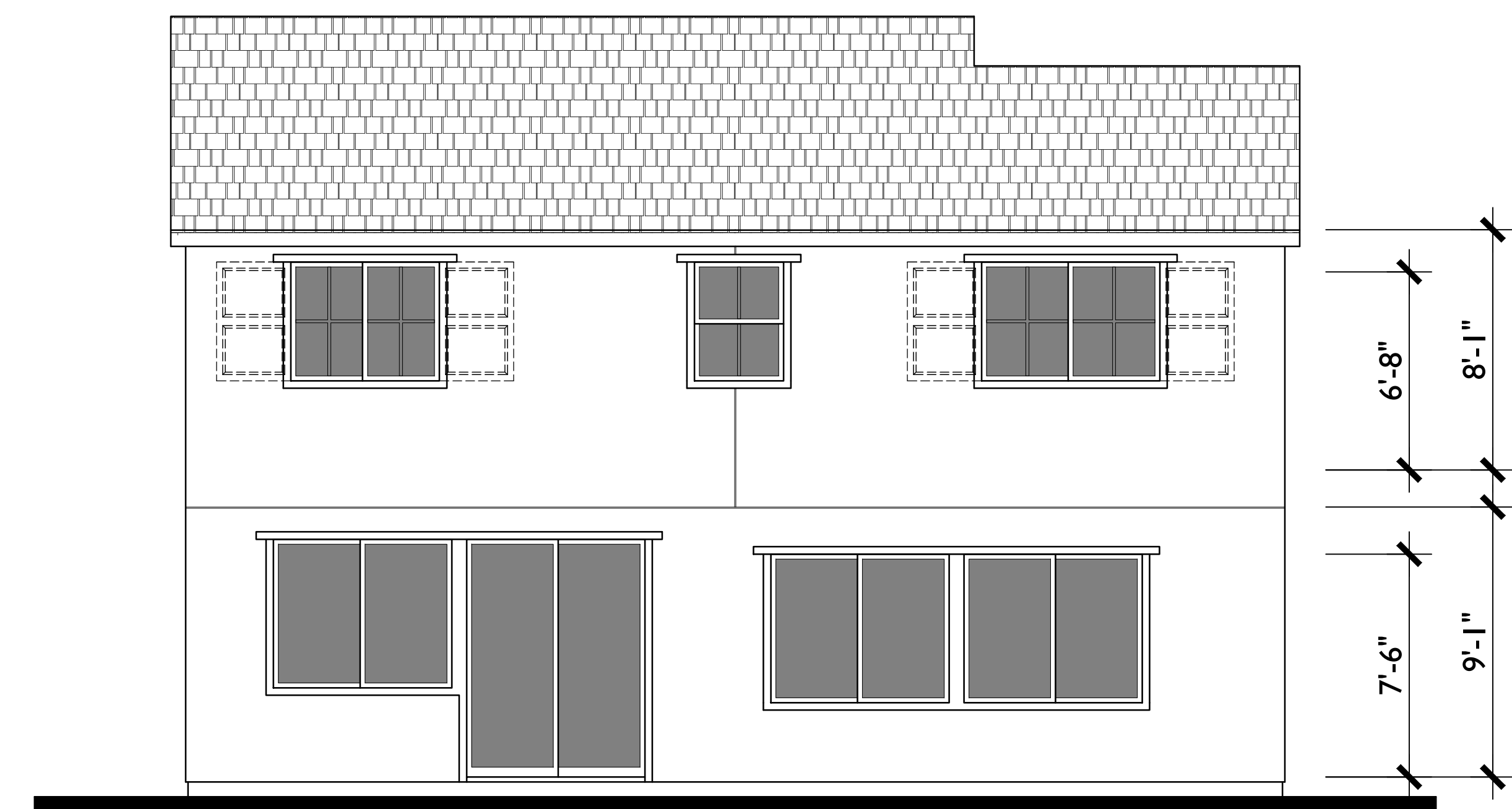

REAR